

P56=P59

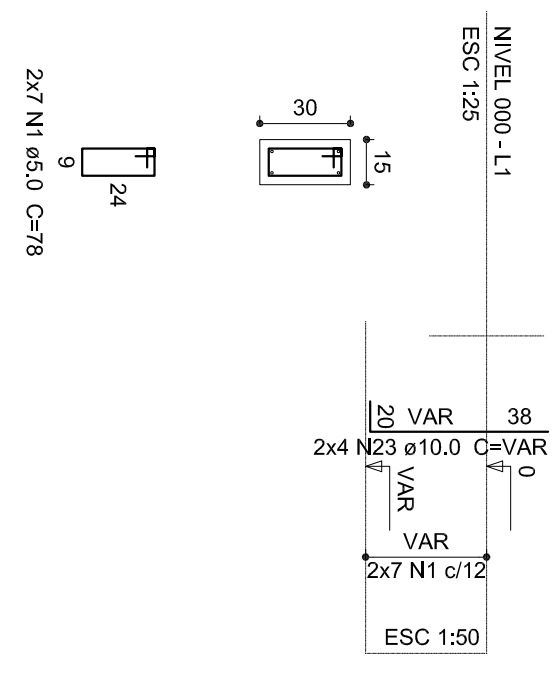

P61

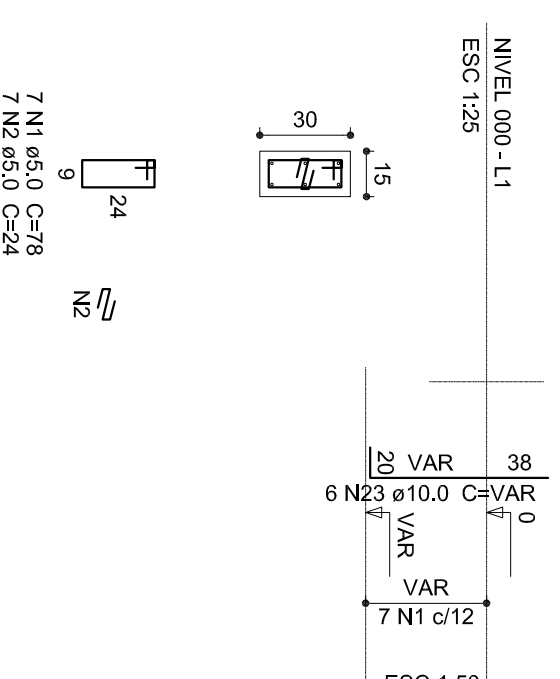

P69=P77=P81=P86=P90=P92=P93=P94=P99=P100

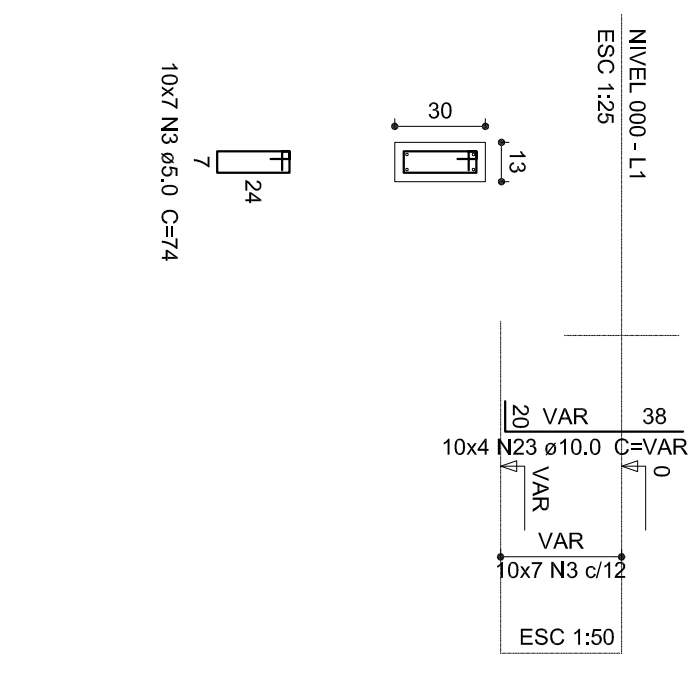

S59=S59=S61=S69=S77=S81=S86=S90

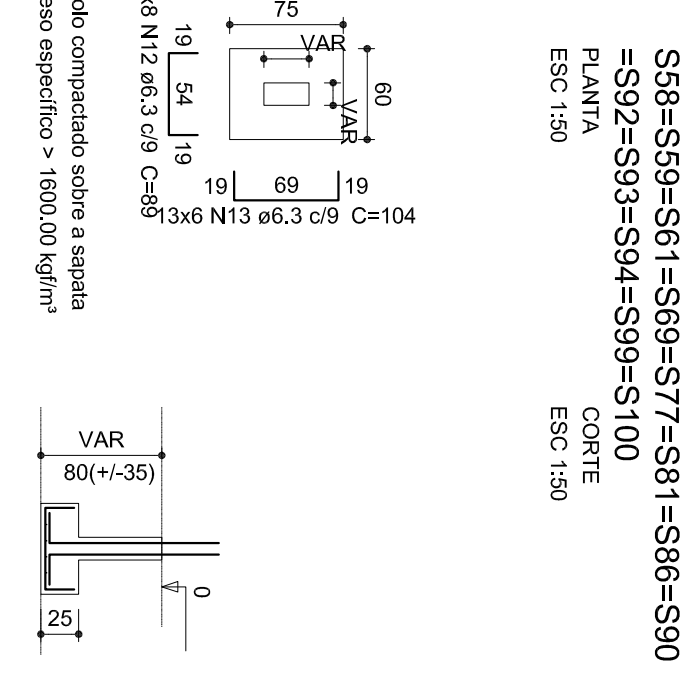

P12=P13=P60

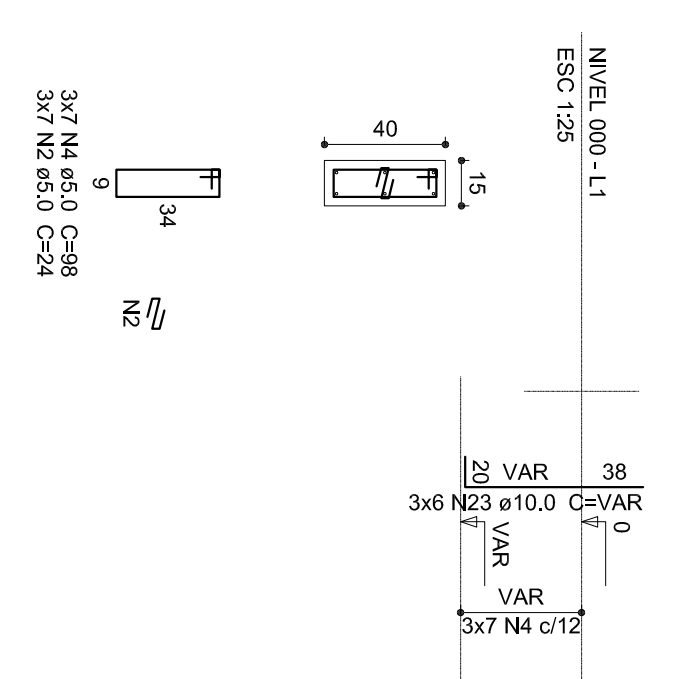

P20=P21=P71=P72=P19=P80=P82=P87=P88=P103

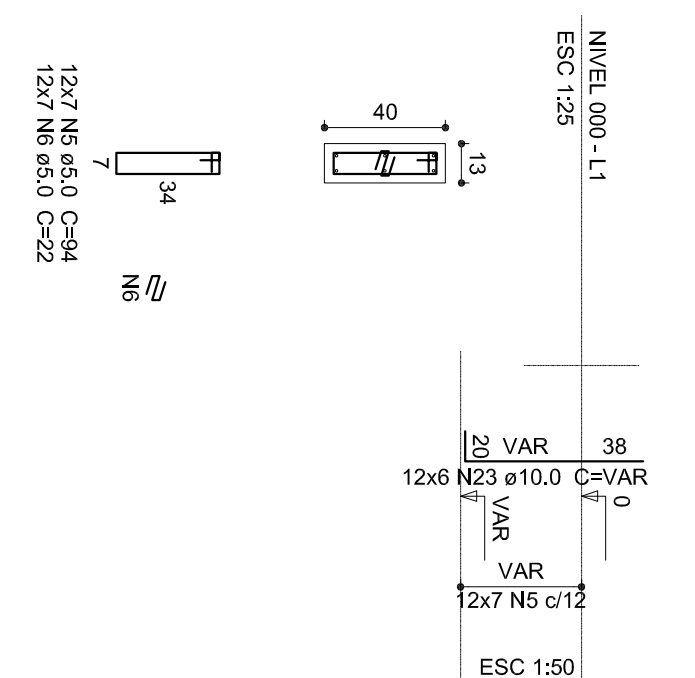

P83=P84

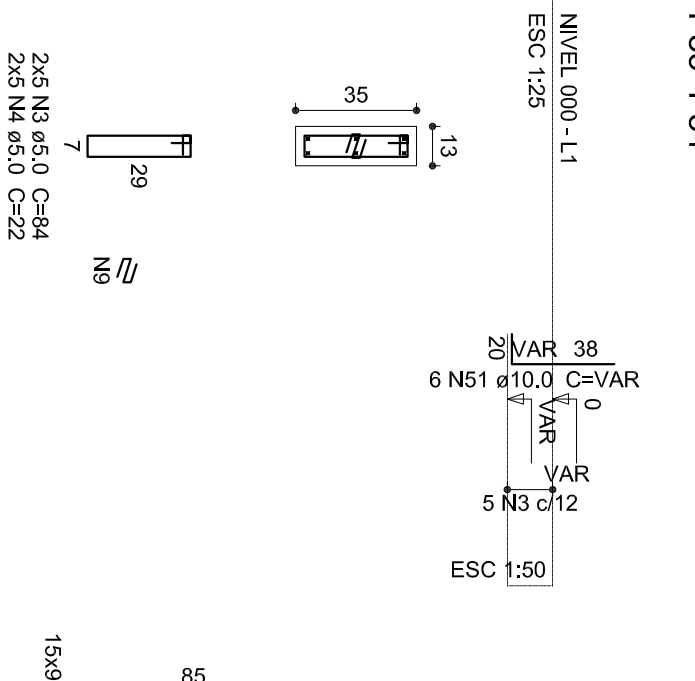

S12=S13=S20=S21=S60=S71=S72=S79=S80=S82

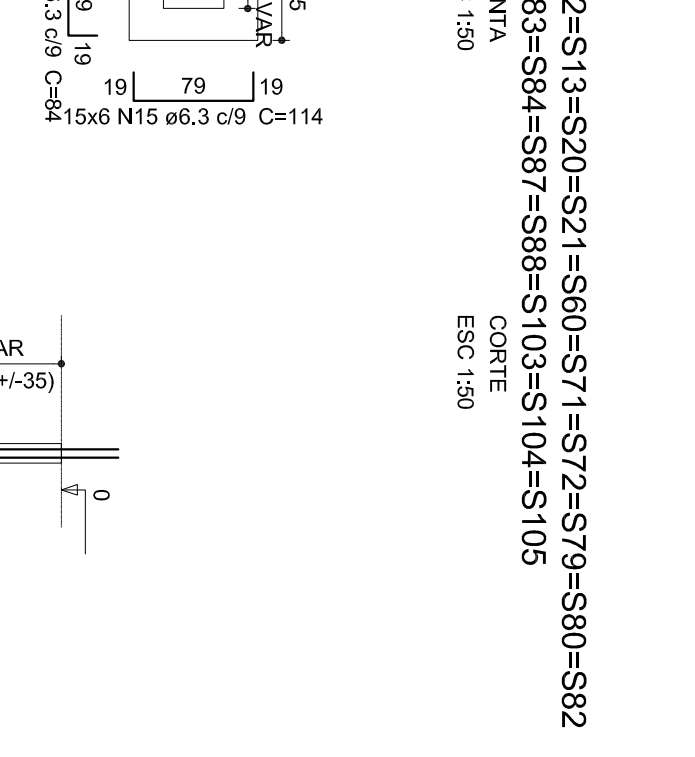

P65=P74=P75

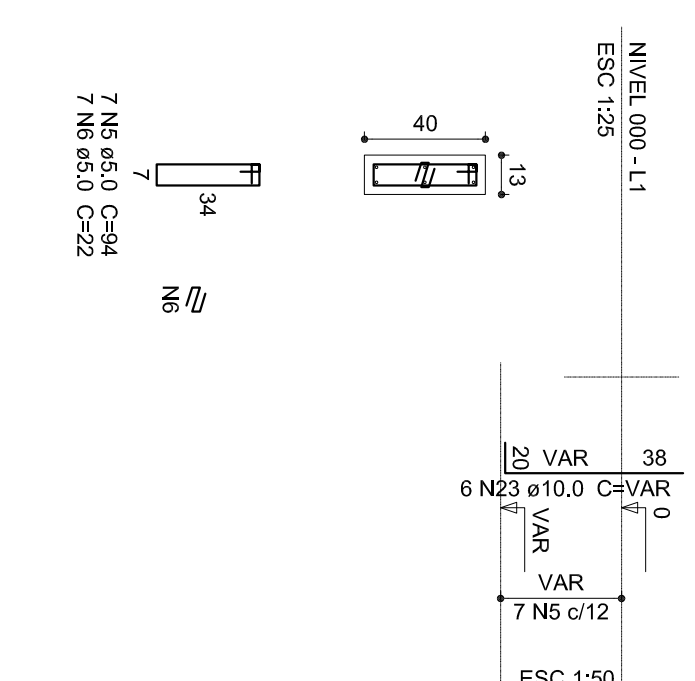

S65=S74=S75

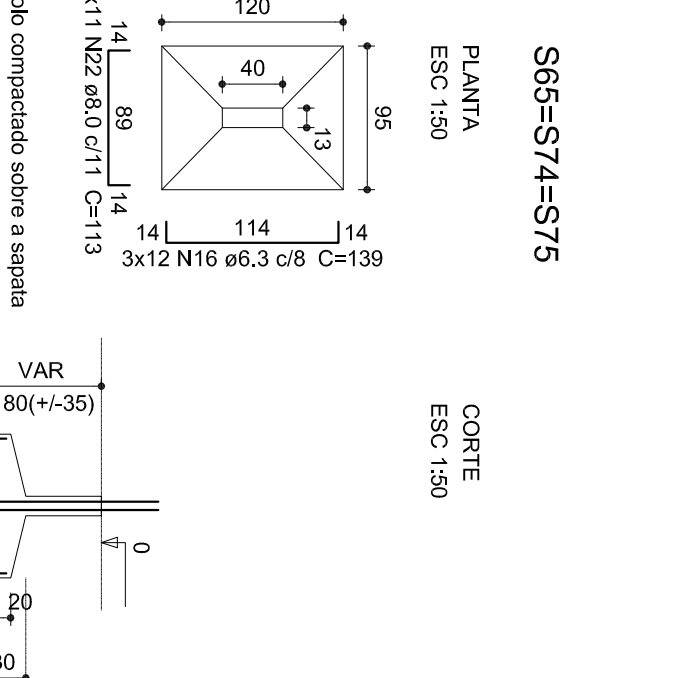

P76=P78=P89=P106

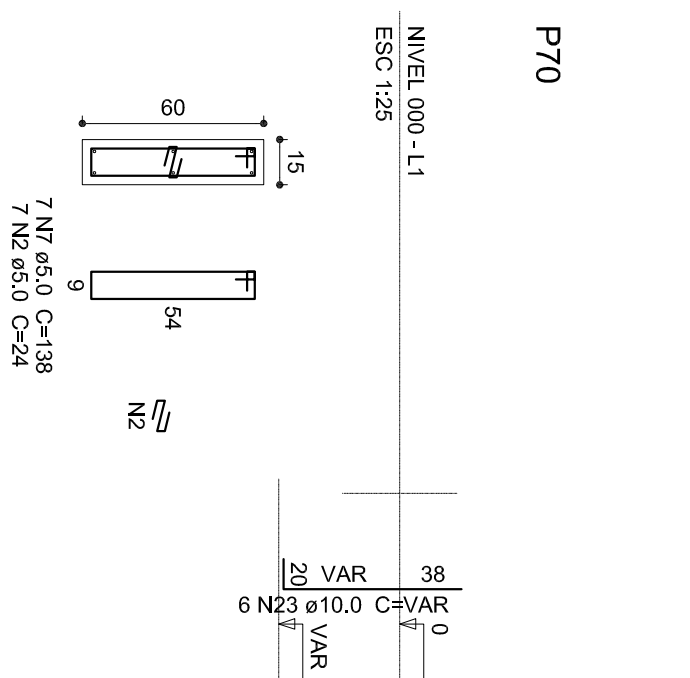

P30

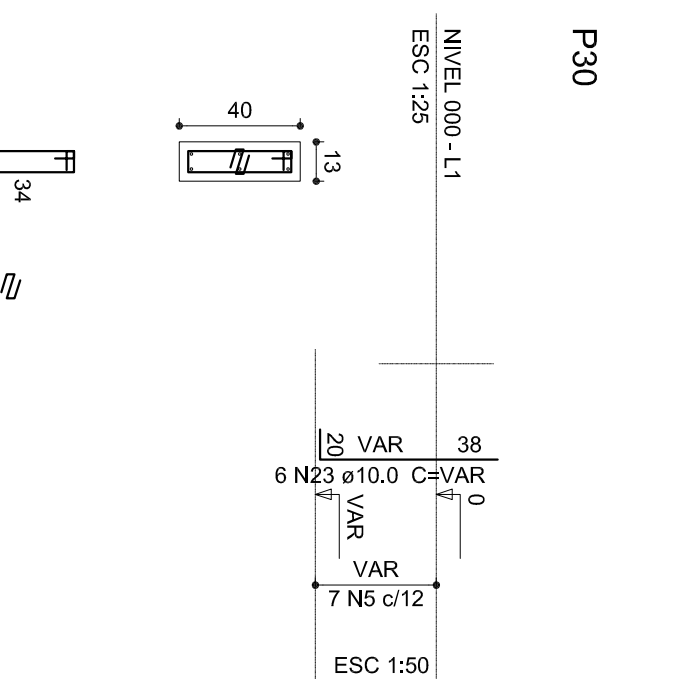

P9=P16

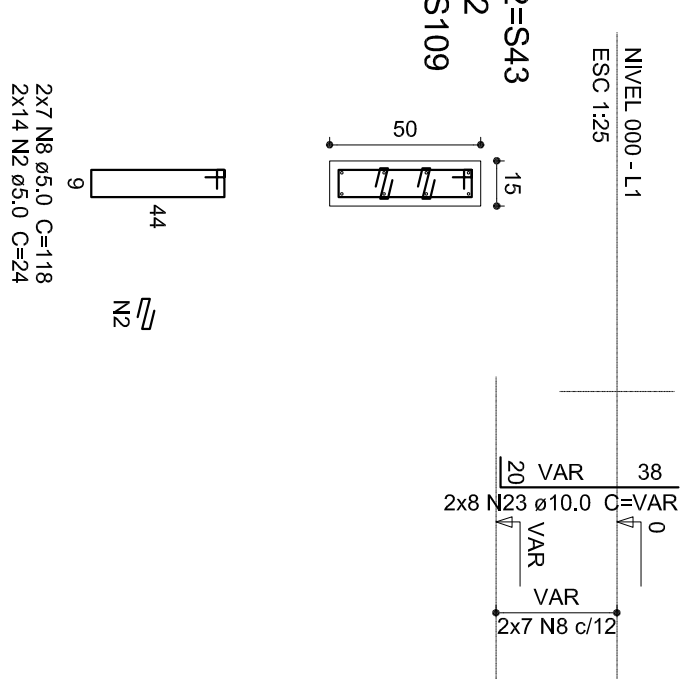

P35

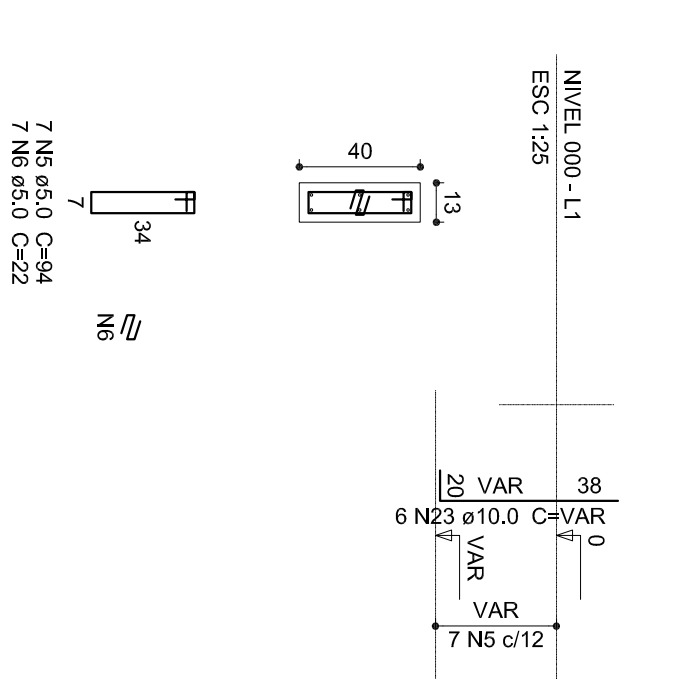

S9=S10=S35

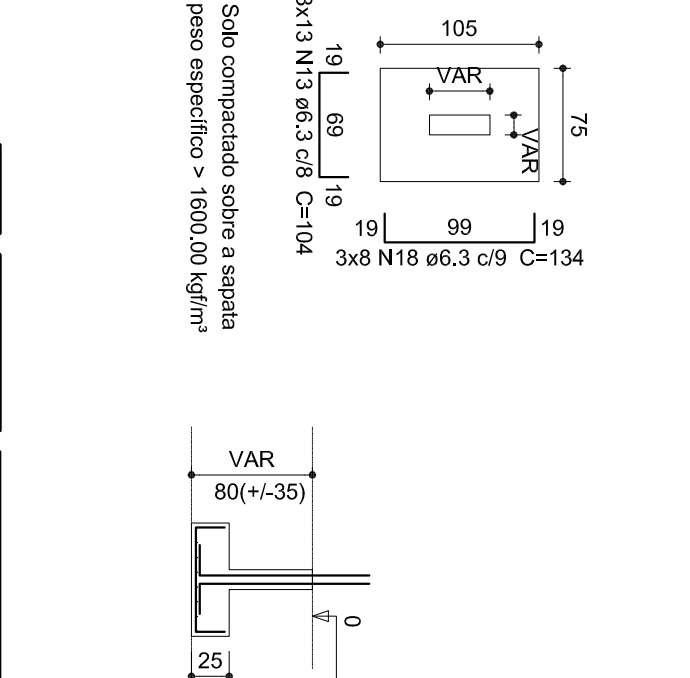

P102

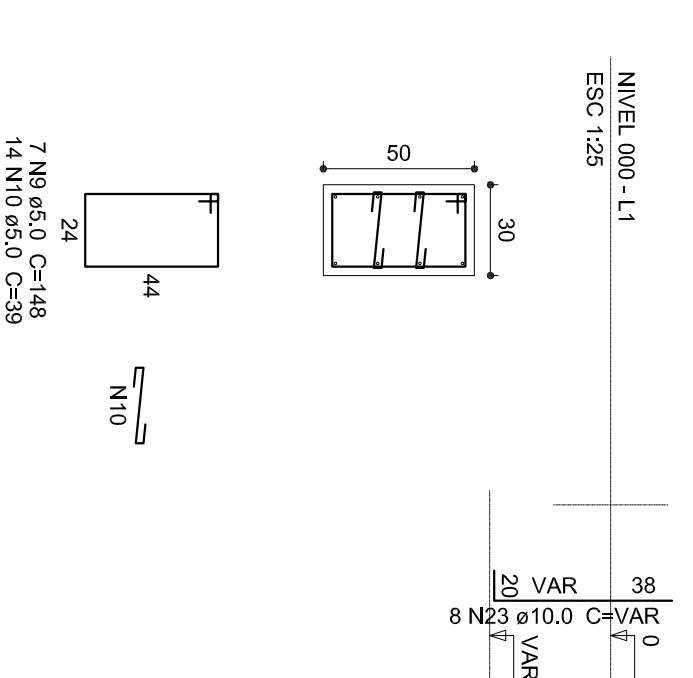

P28=P29

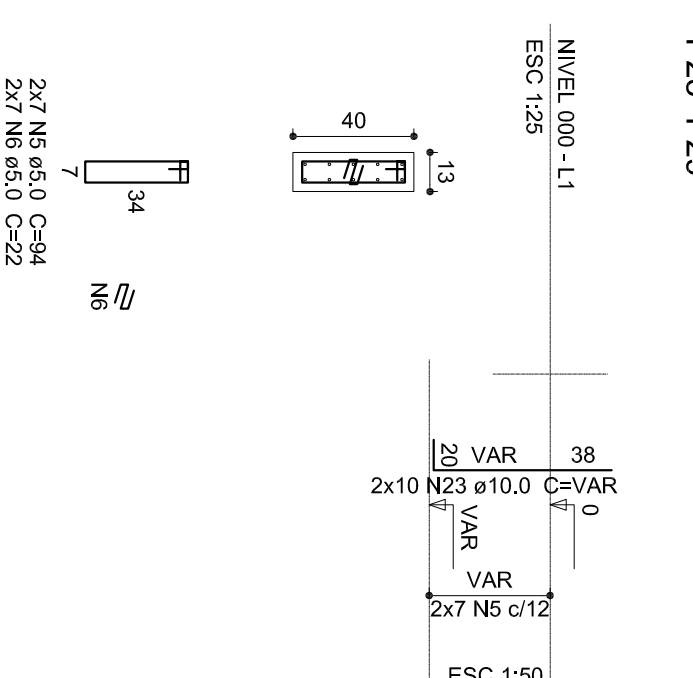

P31

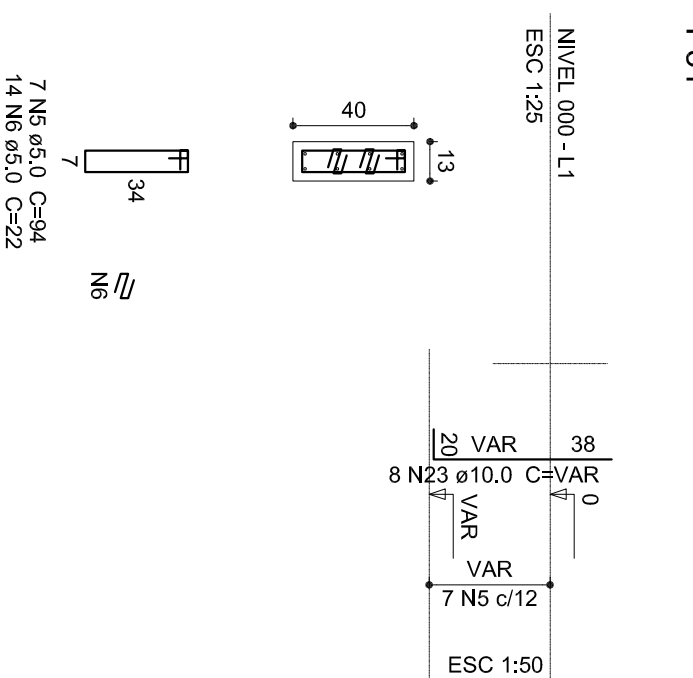

P33

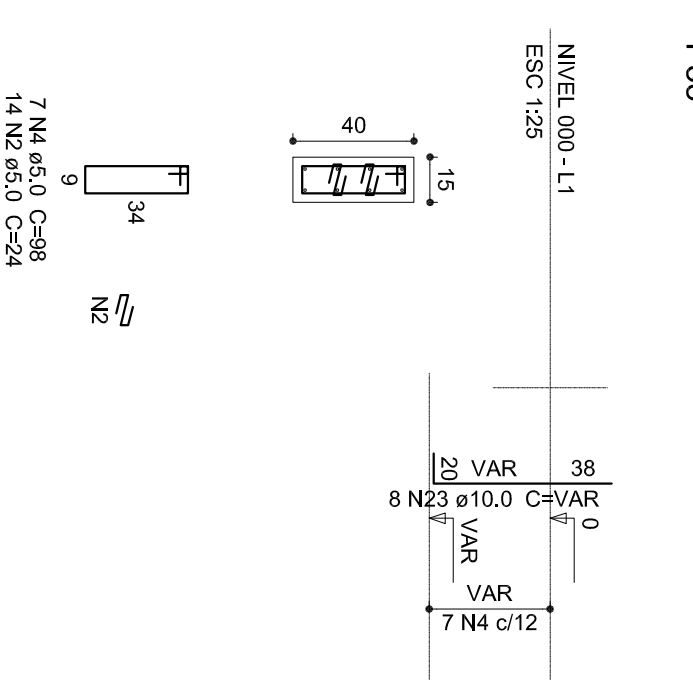

P38=P39

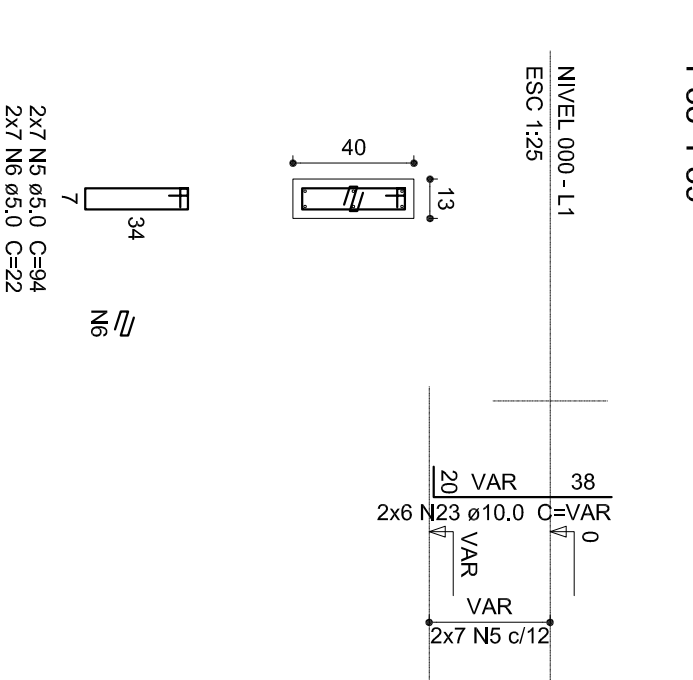

P91

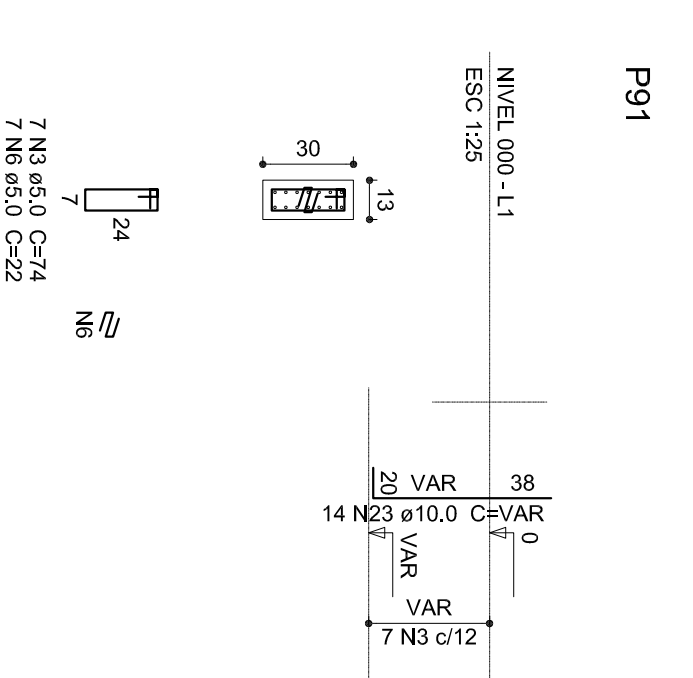

P85

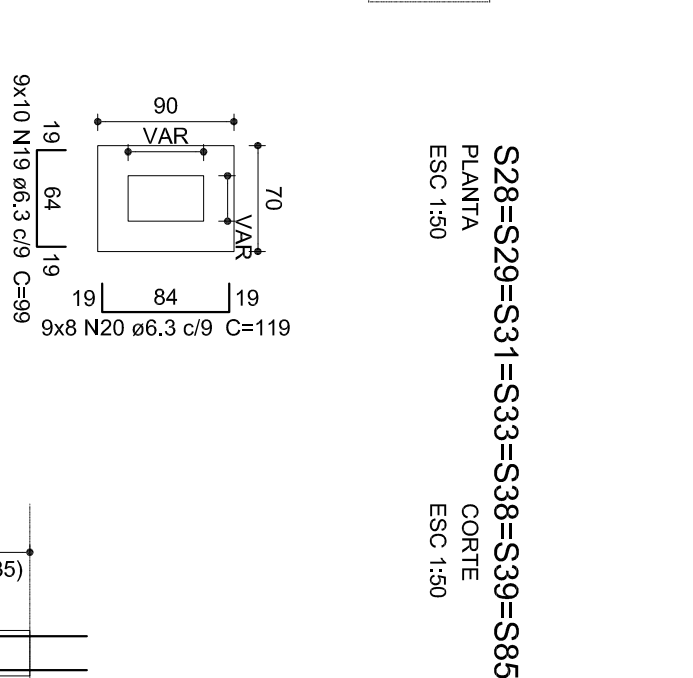

S28=S29=S31=S33=S38=S39=S85=S91=S102

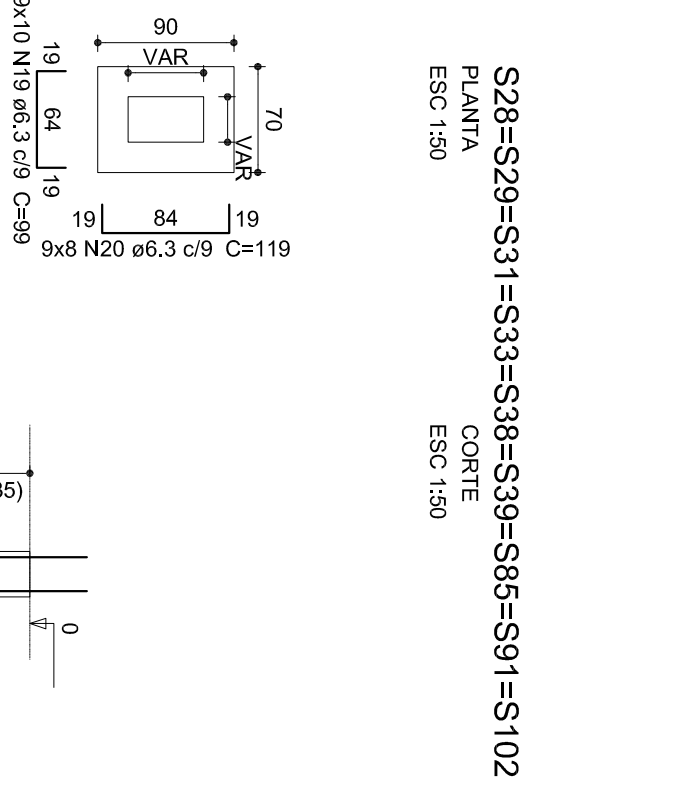

P18

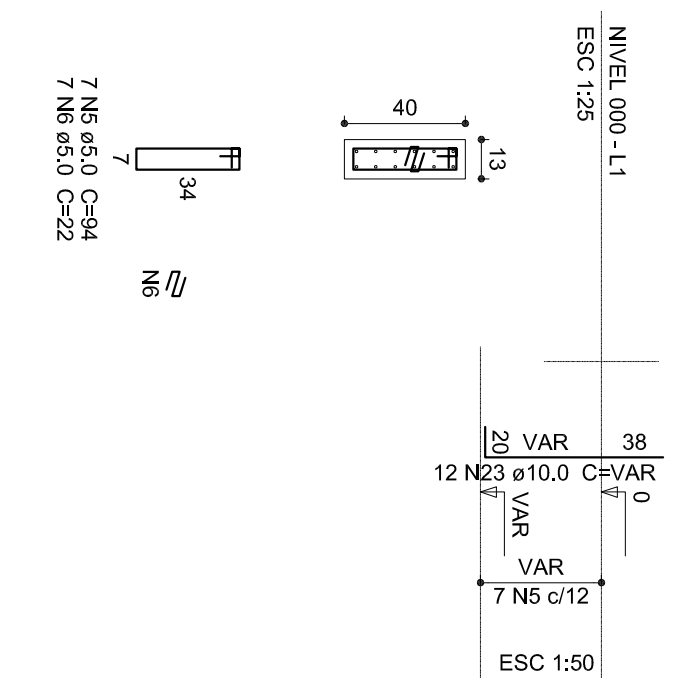

P19=P22

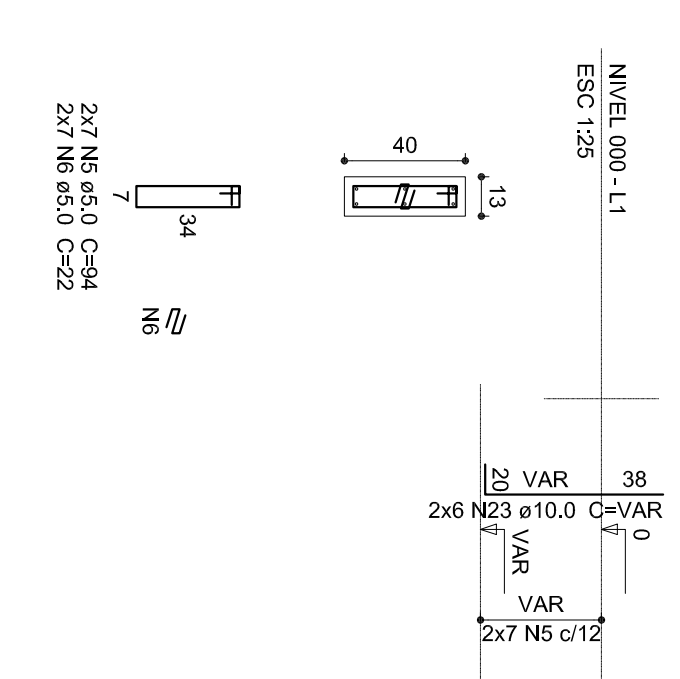

P23

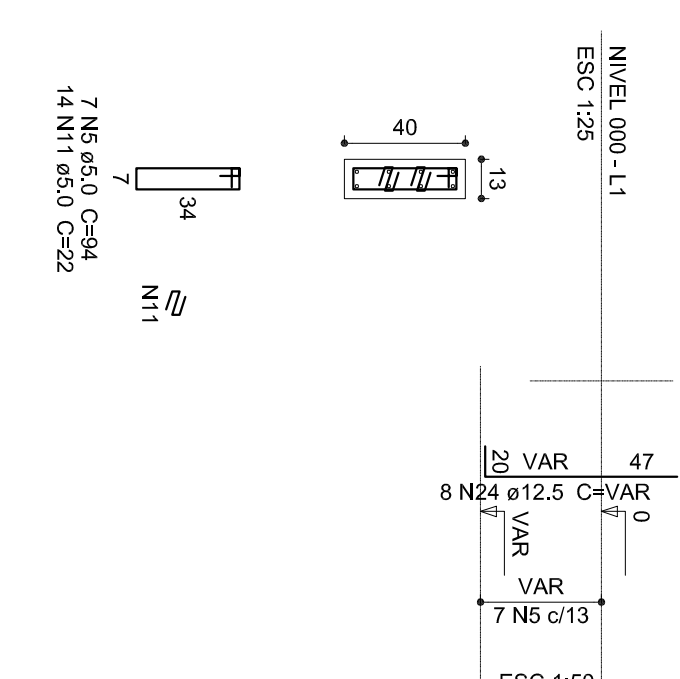

P26

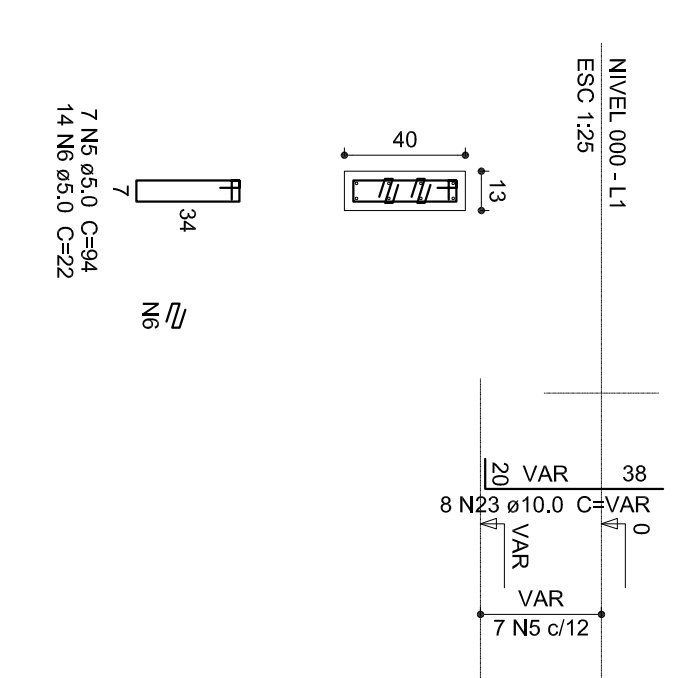

P40

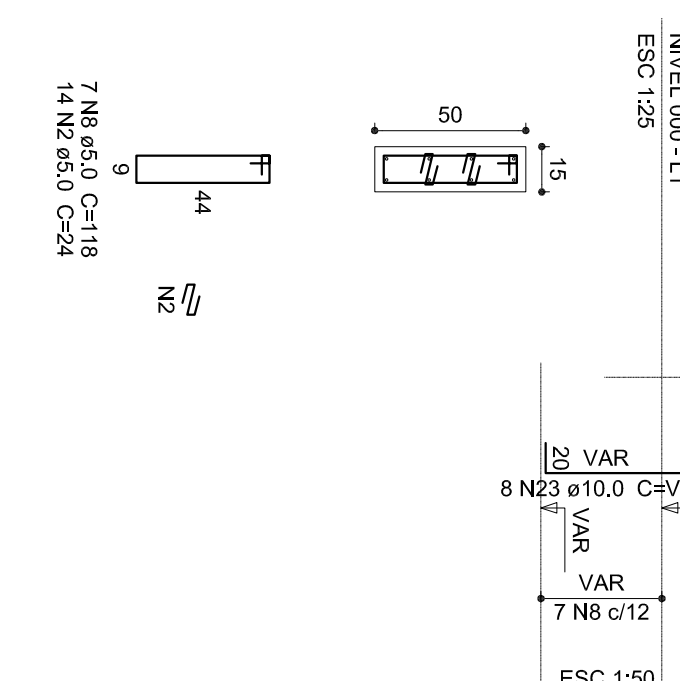

P33

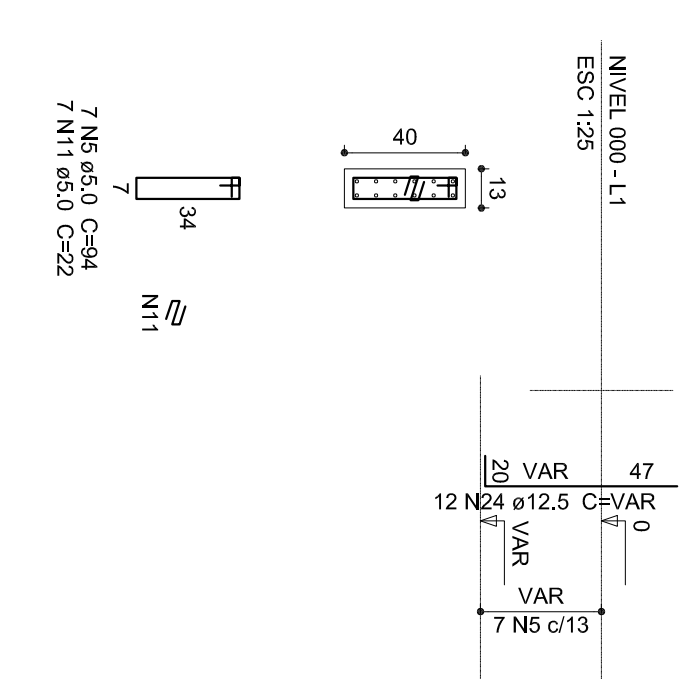

S18=S19=S22=S23=S26=S40=S63

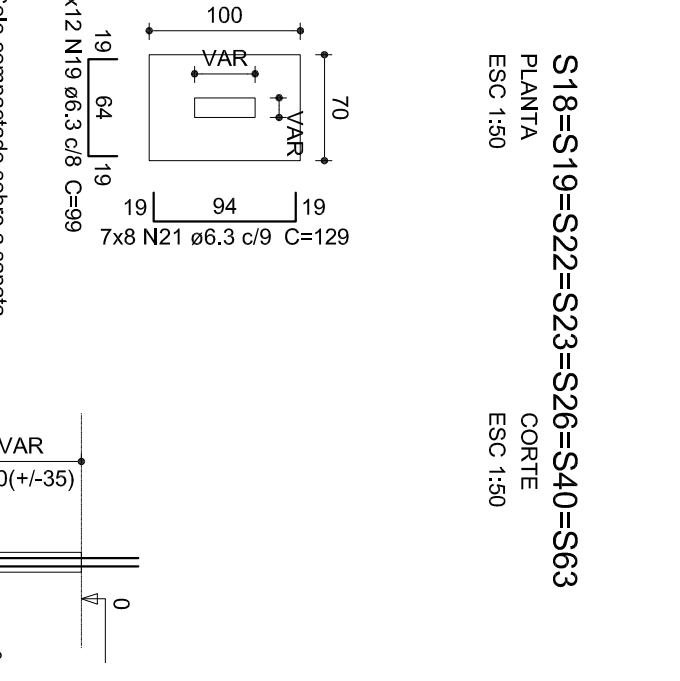

ACO	DIM (mm)	C.TOTAL	PESO (kg)
CA50	8,0	132,2	398,7
CA40	10,0	799,0	488,3
CA80	12,5	28,4	28,3
FESO TOTAL		799,6	1227,1
CA50	889,1		
CA80	1227,1		

Volume de concreto (C25) = 18,35 m<sup>3</sup>  
 Área de forma = 128,10 m<sup>2</sup>

**FNDE** Fundação Nacional de Desenvolvimento

**Ministério da Educação**

**PROJETO PADRÃO - FNDE**

PROPRIETÁRIO: PREFEITURA MUNICIPAL DE MURARÉ

ENDEREÇO: RUA 08, LOTES DE 03 A 14 DA QUADRA N. LOTEAMENTO DORNELIAS II, MUNICÍPIO - UF: MURARÉ - MS.

Rua: Rui Barbosa, Vila Esper

RESP. TÉCNICO E AUTOR DO PROJETO: CREA/MT: 02874/D

PREFEITURA MUNICIPAL DE MURARÉ

DUFO

CREA

PROGRAMA PROINFANCIA - PROJETO TIPO 1

PROJETO DE ESTRUTURA

FUNDAÇÃO DIRETA

FUNDAÇÃO SAPATAS

DETALHAMENTO DAS SAPATAS

SFS

PROJETO (1995/9594)

INDICADA

JAN/2017

02/17