

# DETALHAMENTO DAS VIGAS DO TÉRREO (02-02)

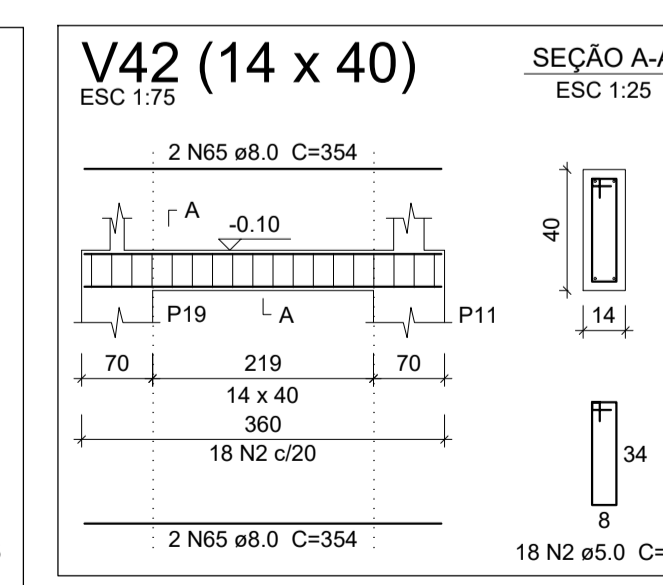
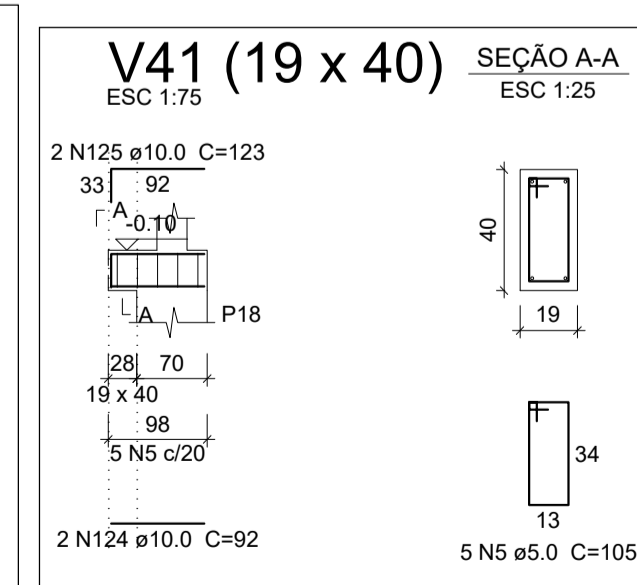
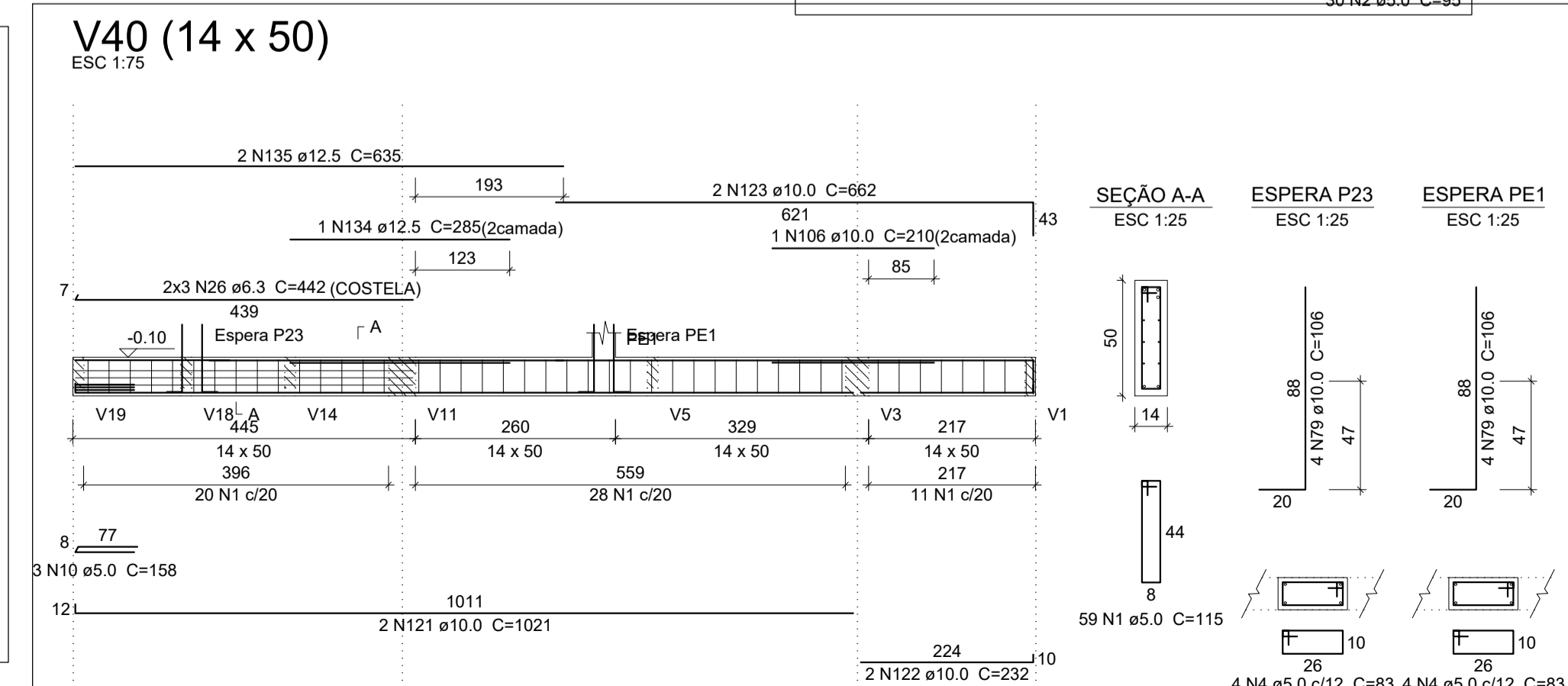
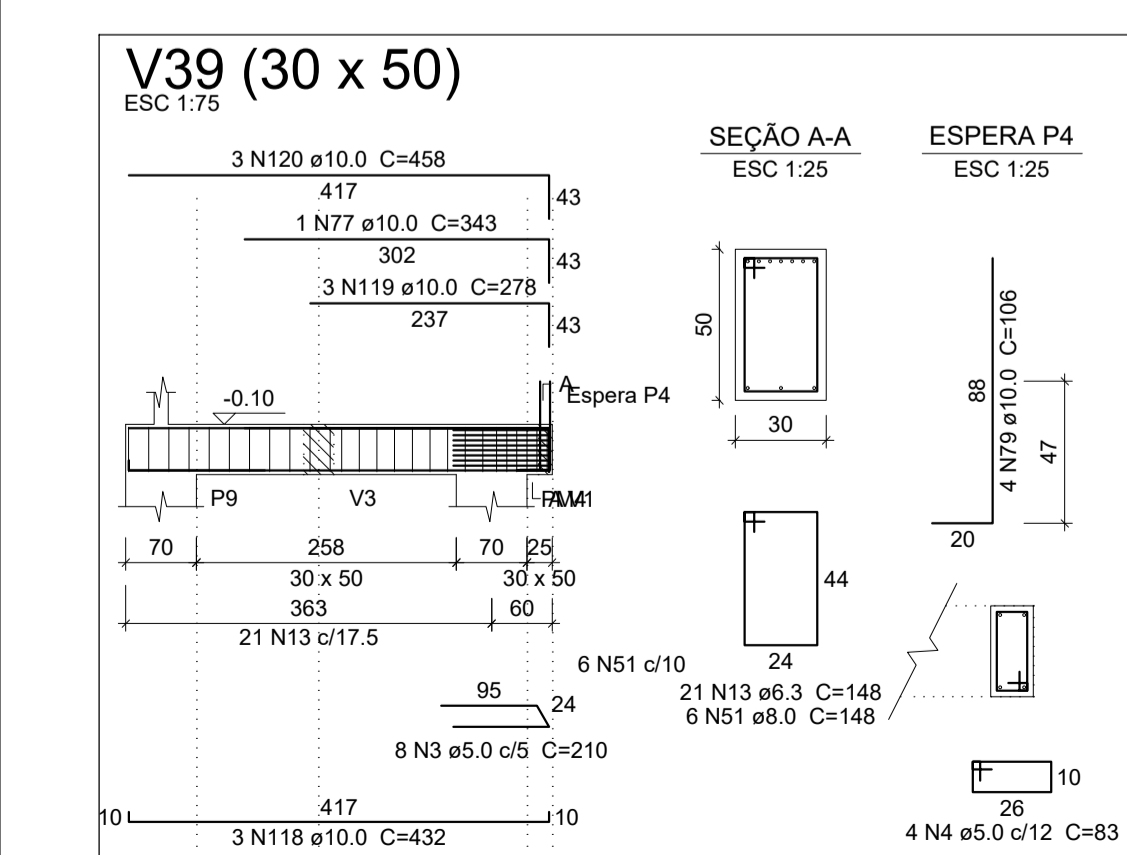
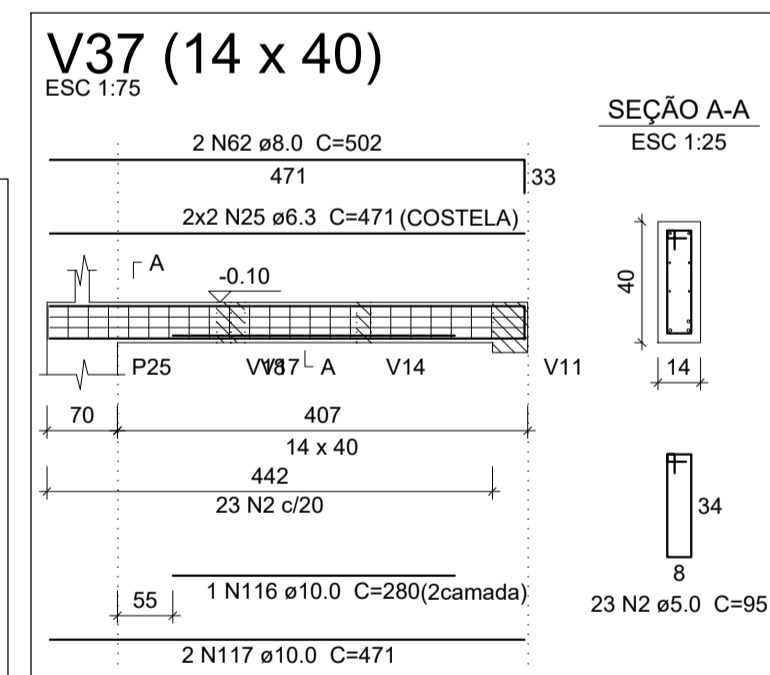
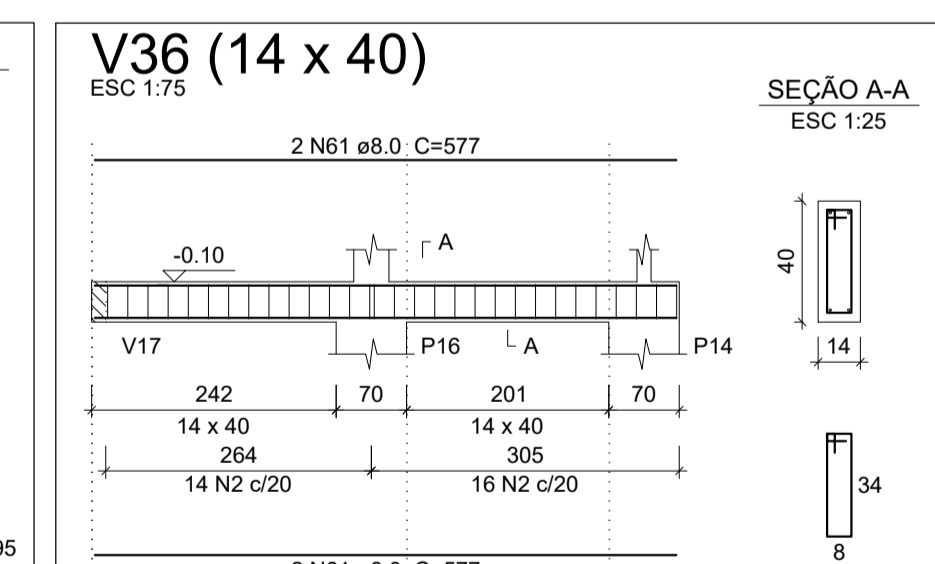
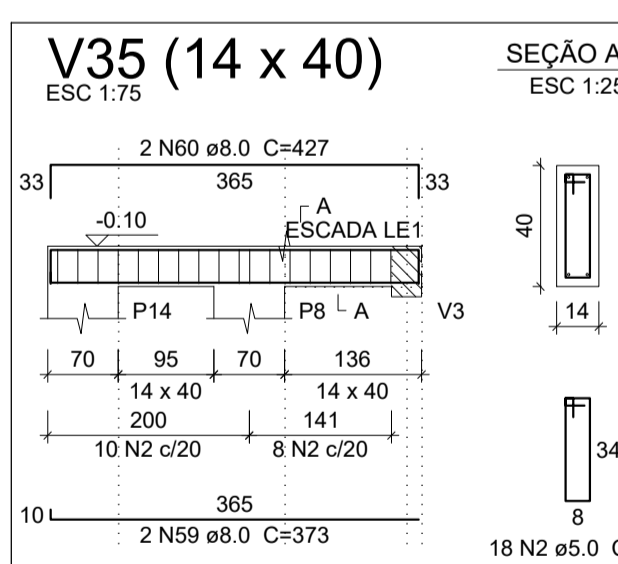
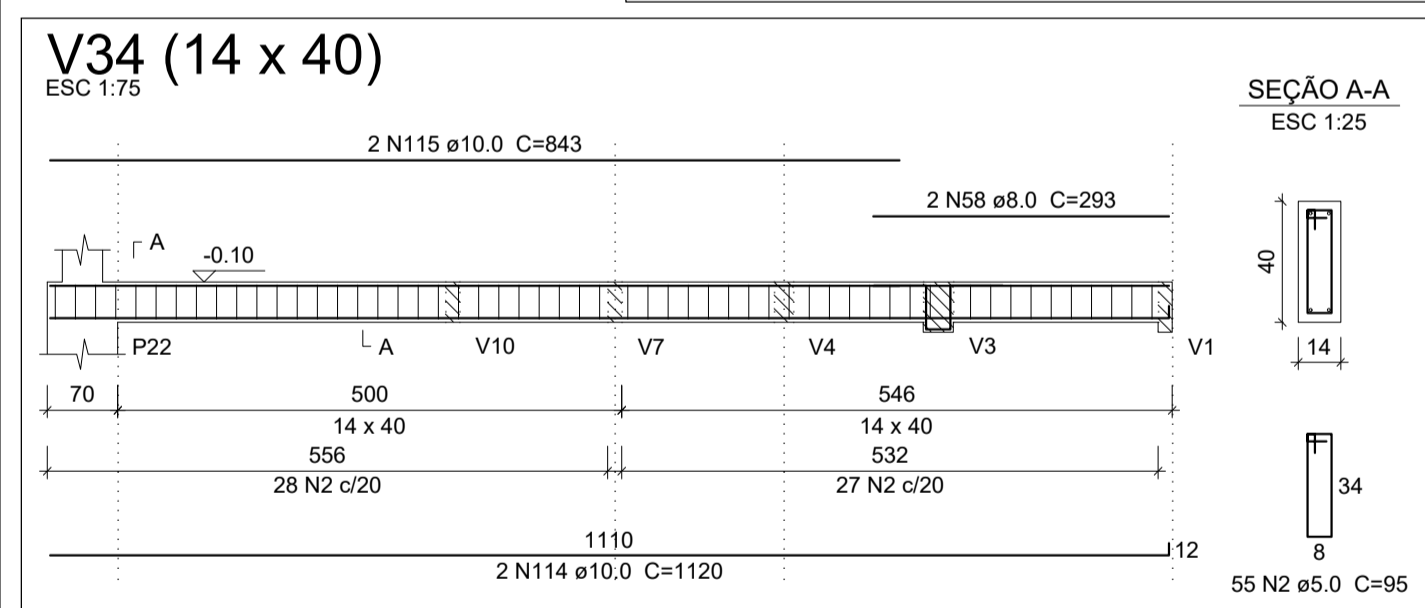
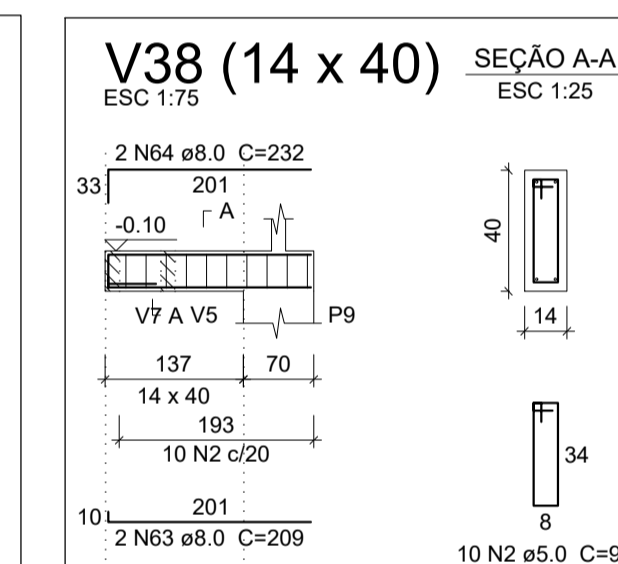
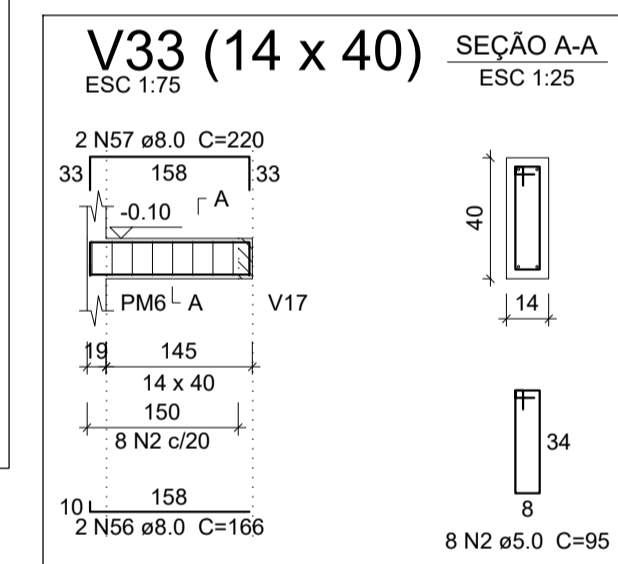
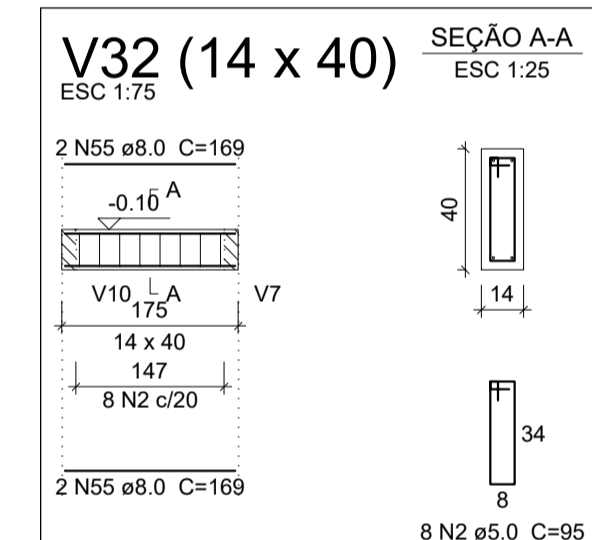
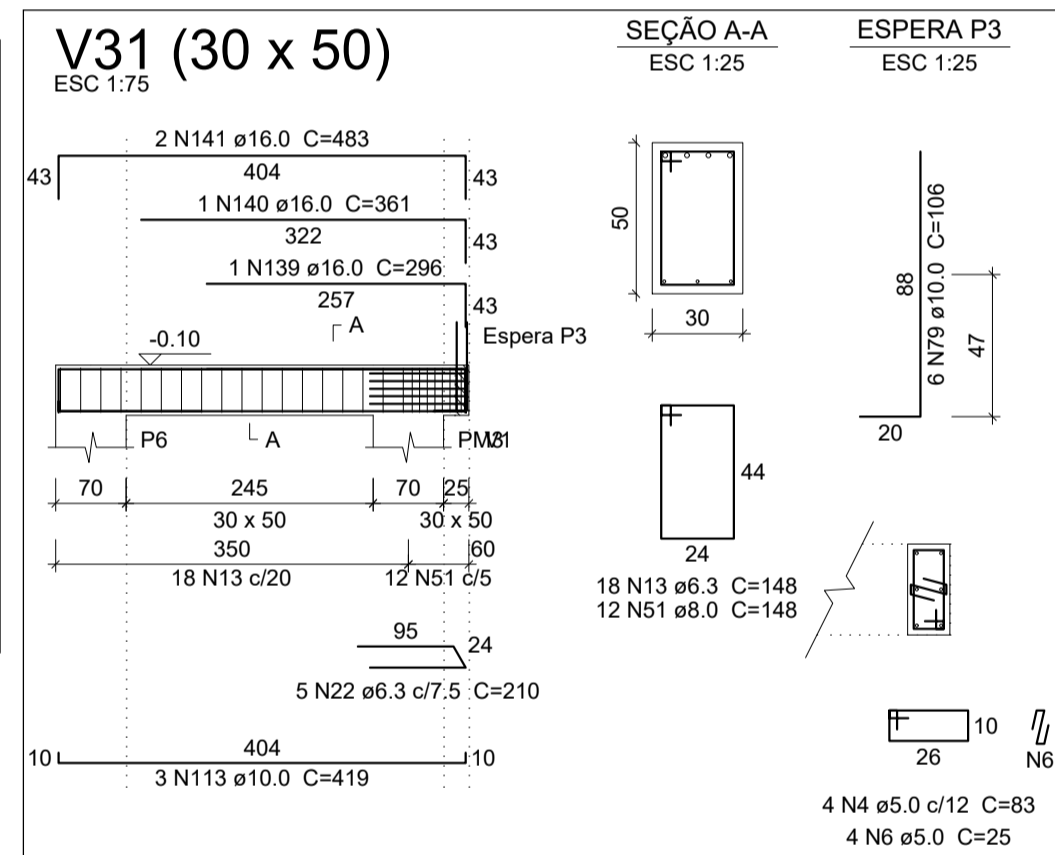
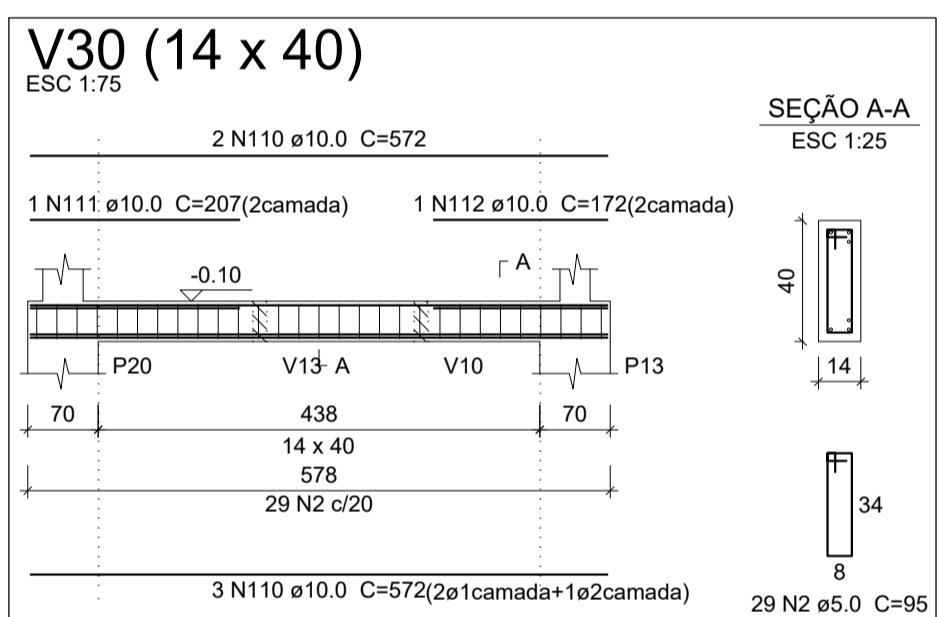
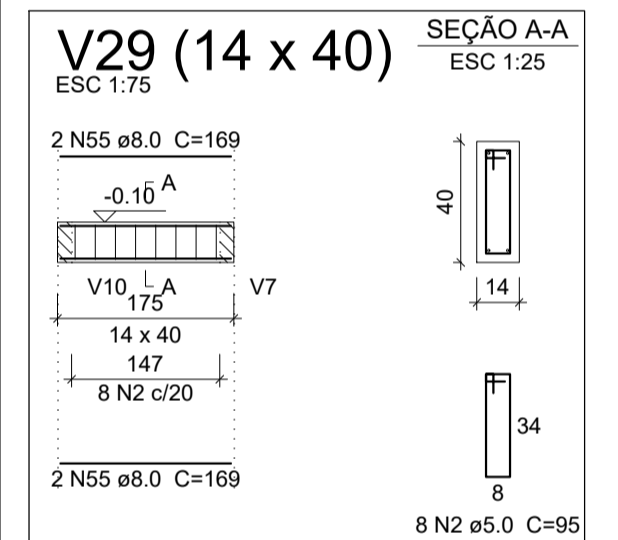
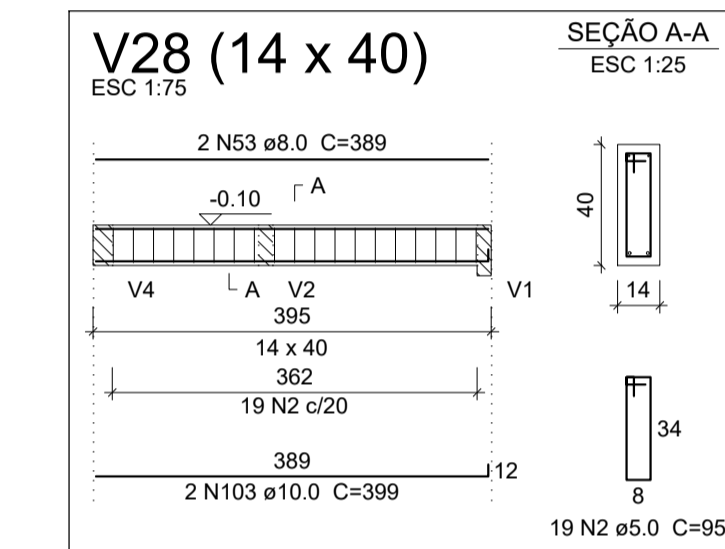
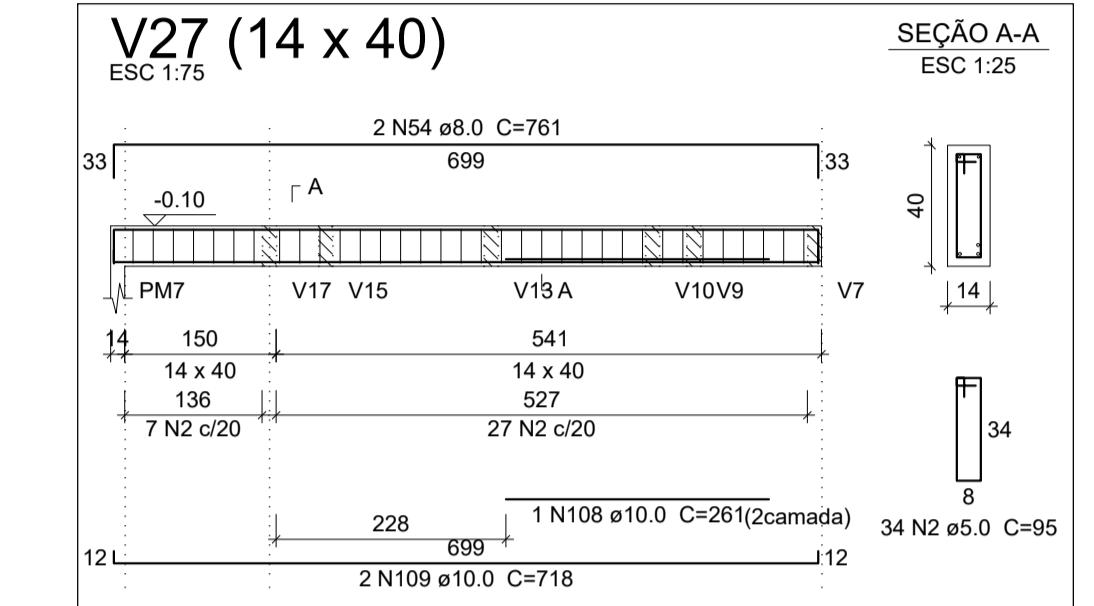
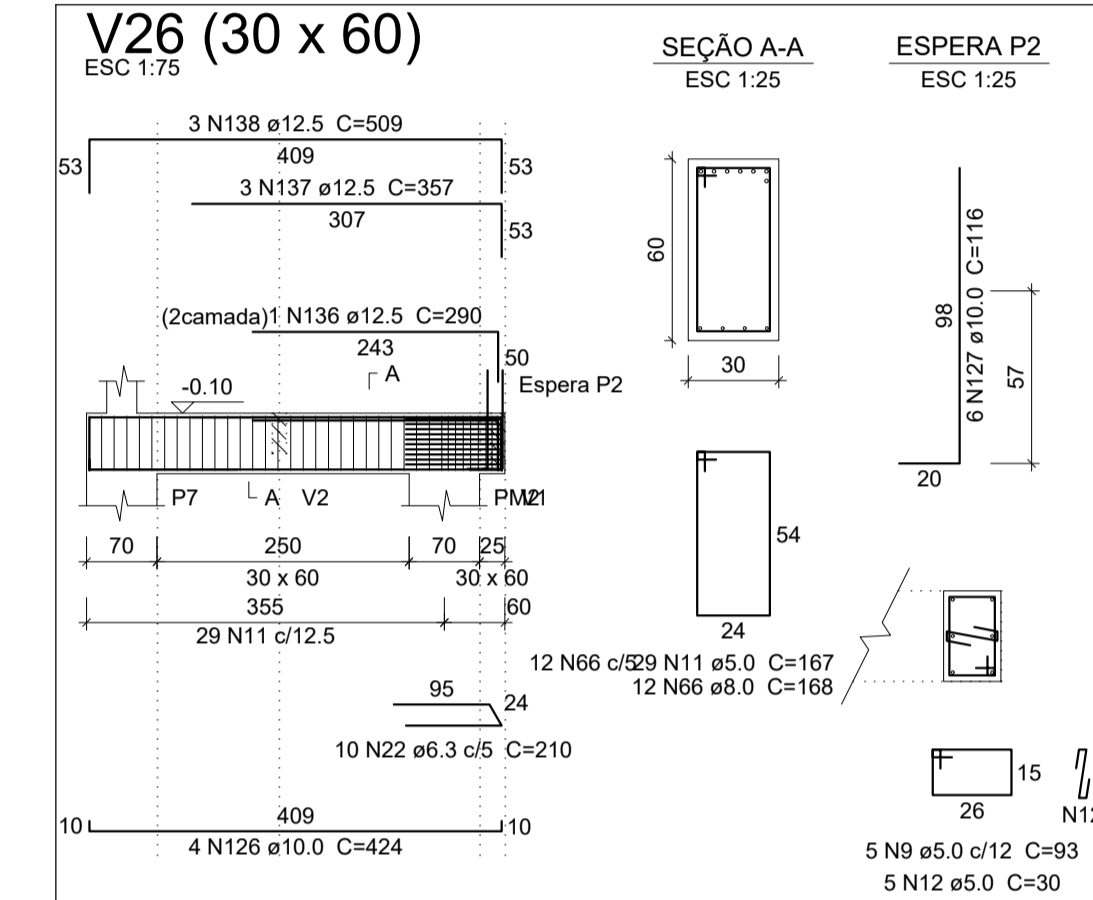
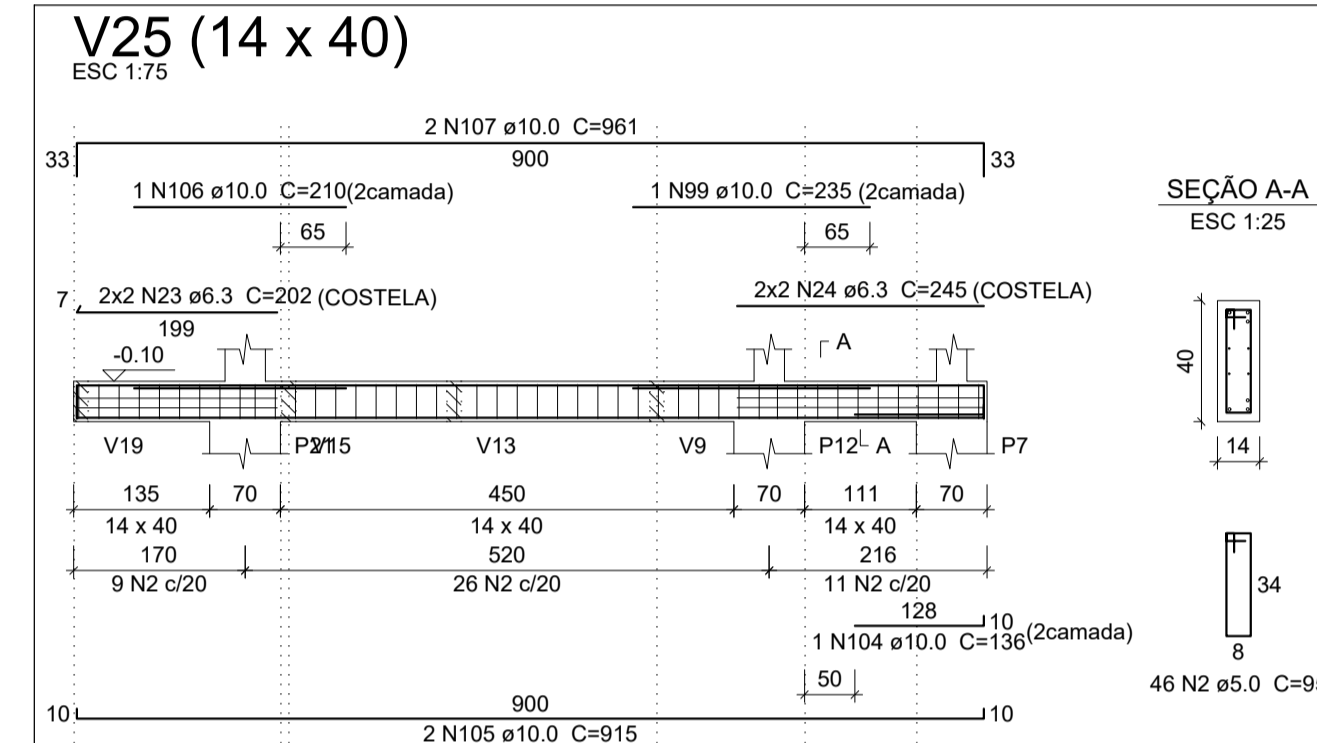
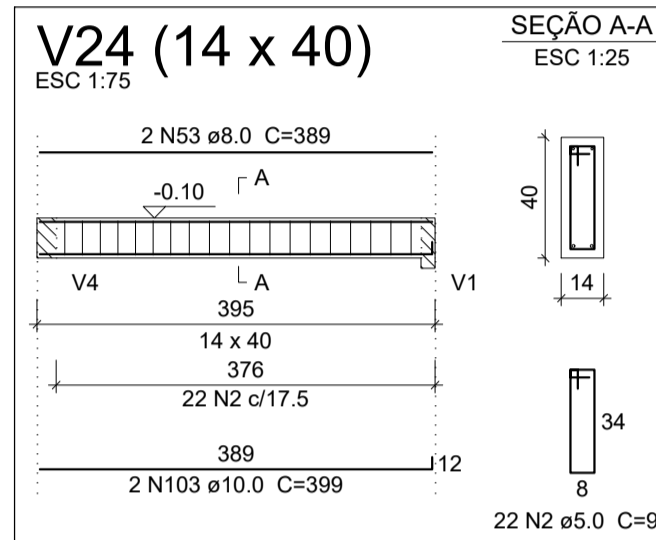
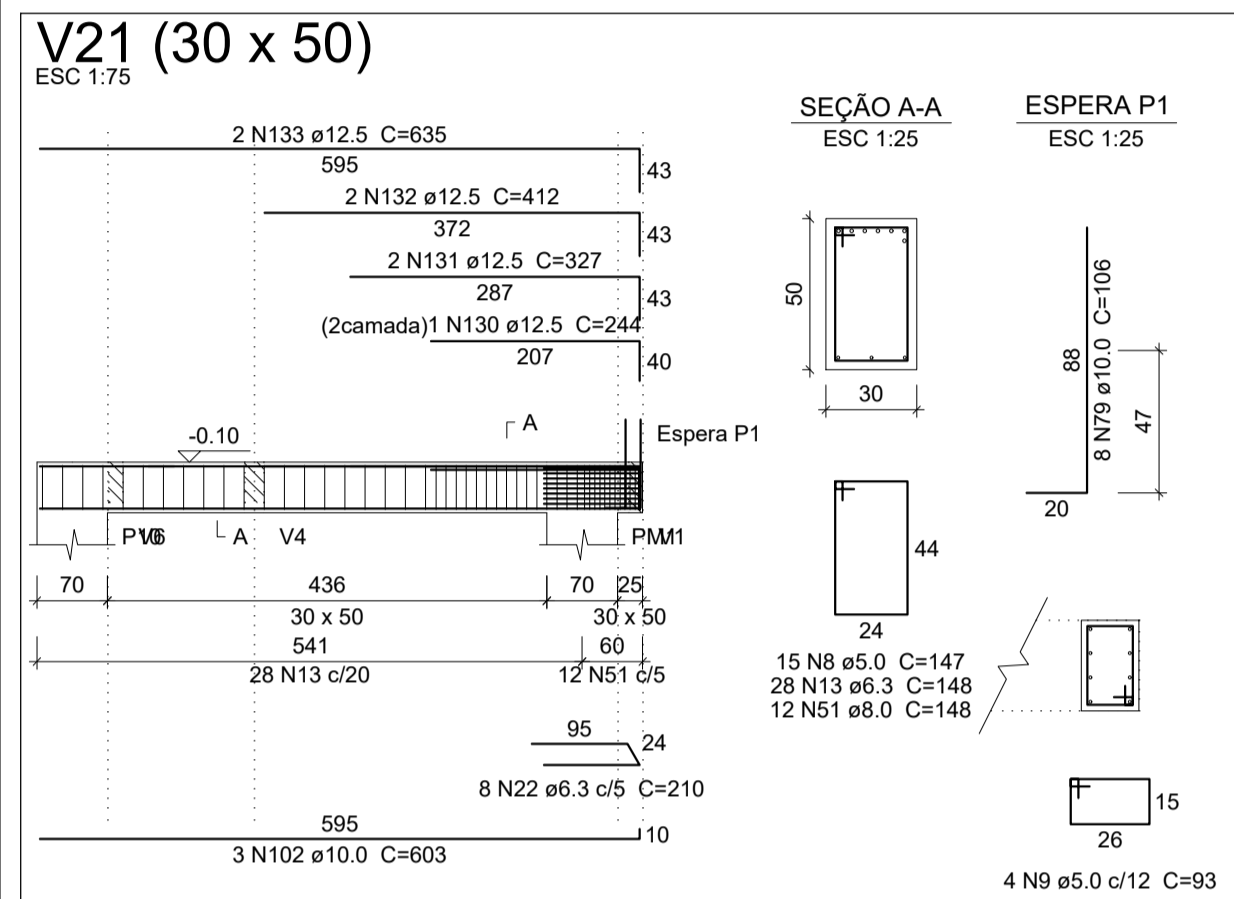
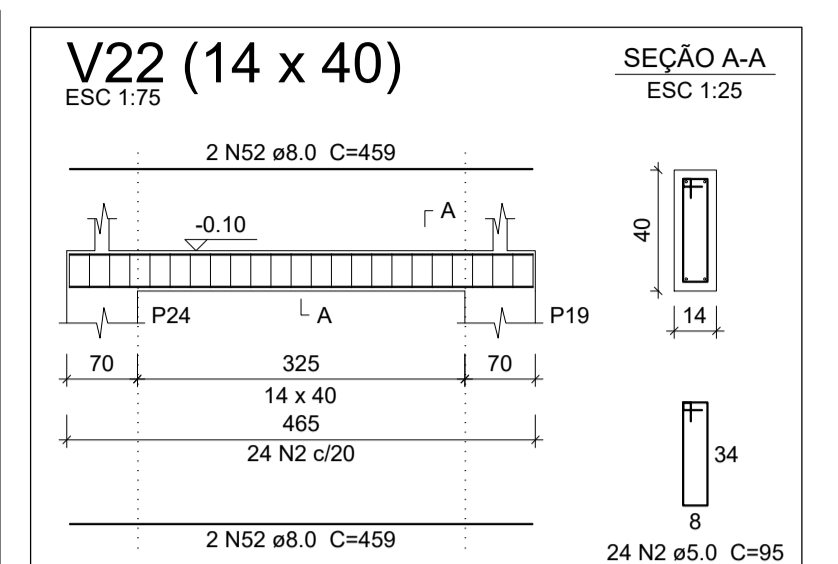
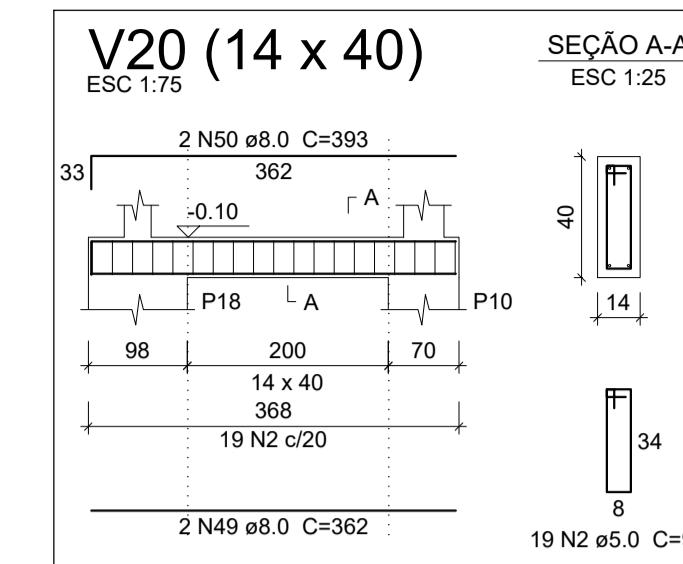
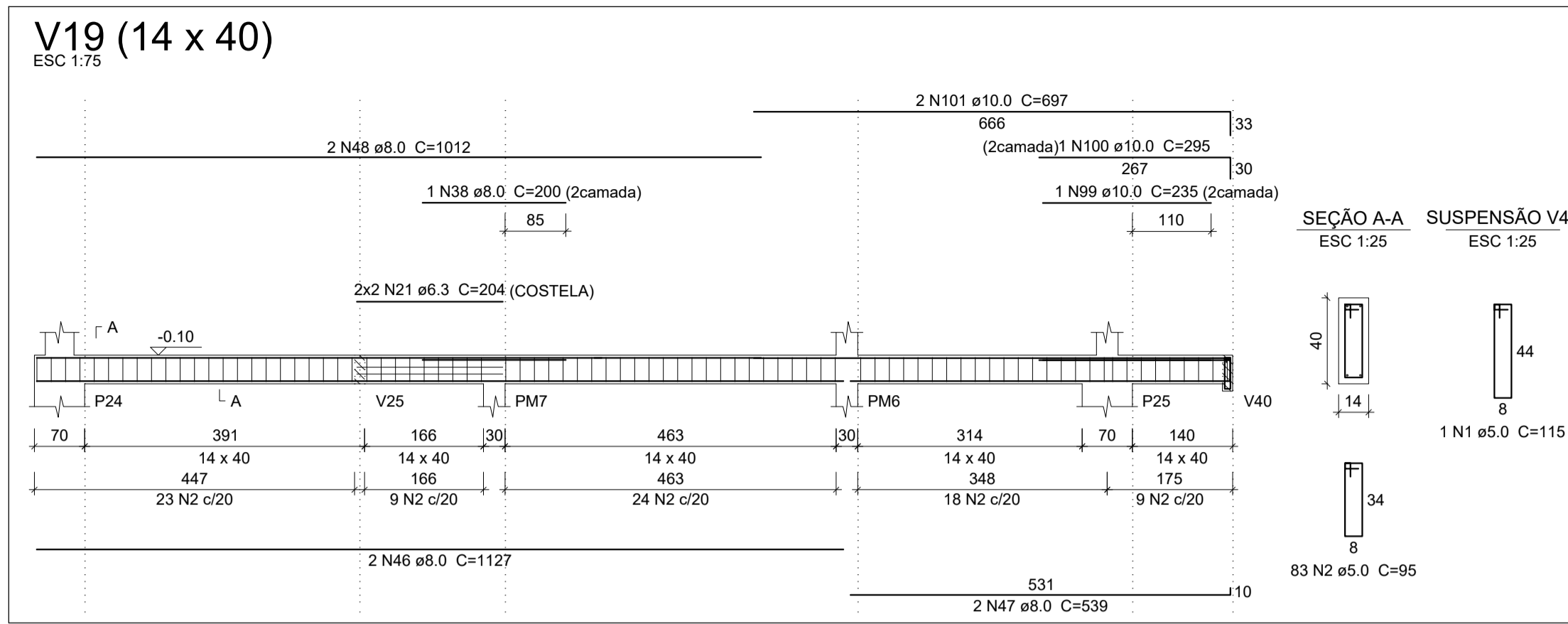
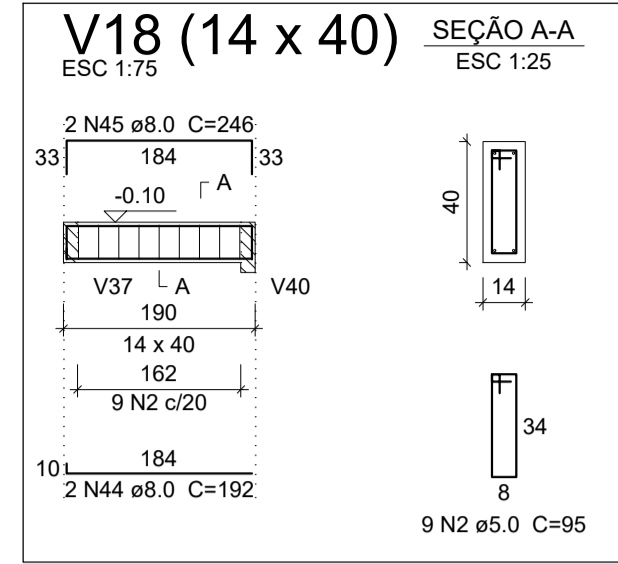
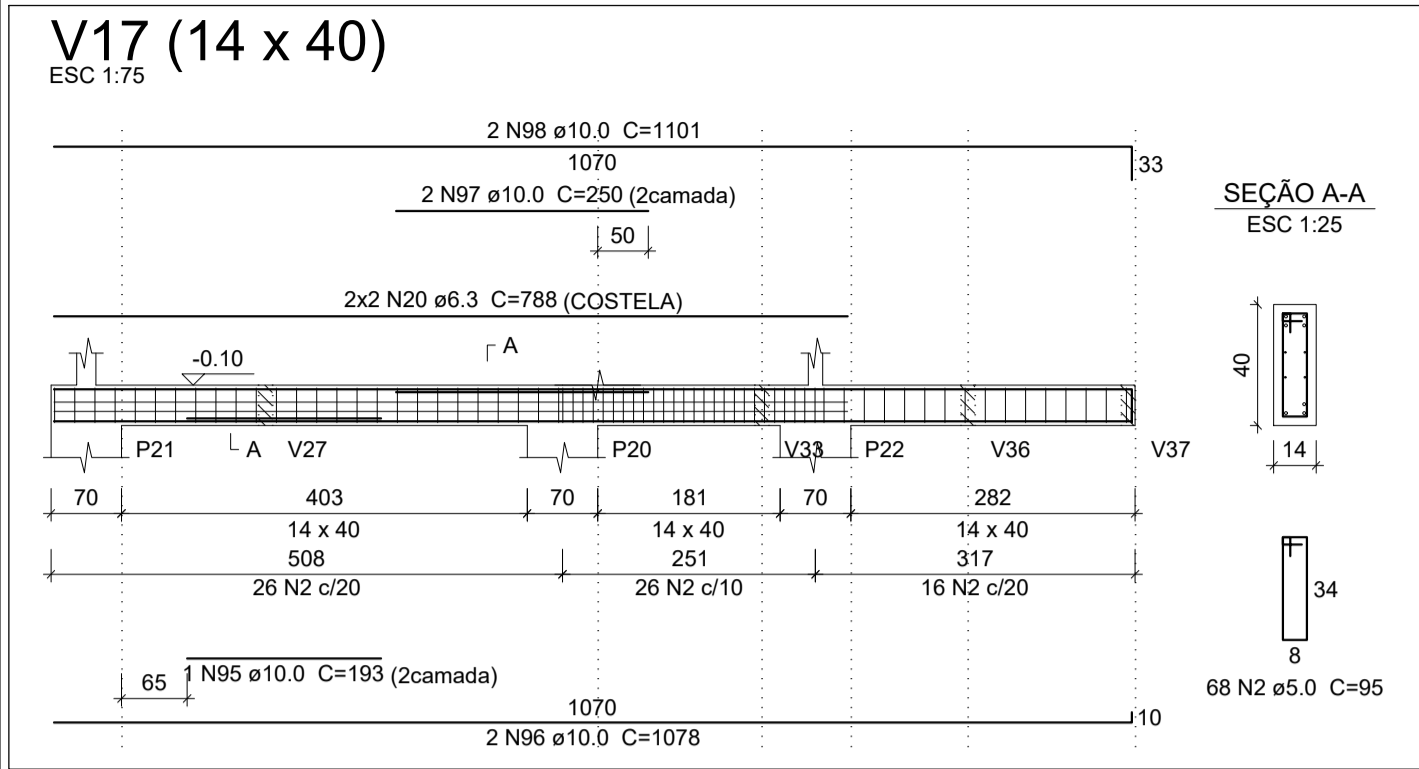

LEGENDA:

- 1 - CONCRETO: 25 MPA
- 2 - ESTE PROJETO FOI DESENVOLVIDO DE ACORDO COM A NBR 6118, E PRESSUÕE UMA EXECUÇÃO BASEADA NAS NORMAS BRASILEIRAS VIGENTES.
- 3 - NENHUMA REPRODUÇÃO E/OU ALTERAÇÃO NESTE PROJETO PODERÁ SER FEITA SEM A PRÉVIA AUTORIZAÇÃO
- 4 - ALVENARIA DE TIJOLO CERÂMICO DE 14 CM DE ESPESURA + REVESTIMENTO
- 5 - SOBRECARGA = 200kg/m2; REVESTIMENTO = 120KG/M2
- 6 - FUNDAÇÕES APOIADAS A 08 METROS; DIMENSIONAMENTO REALIZADO DE ACORDO COM O FURO 01 DO LAUDO DE SONDEAGEM Nº 22-014, FORNECIDO PELA EMPRESA RJ ENGENHARIA

TABELA DE COBRIMENTOS		CONTROLE RIGOROSO	
ELEMENTO	FUNDAÇÕES	VIGAS	PILARES
COBRIMENTO	4,5 cm	3,0 cm	2,0 cm
			2,0 cm

Projeto:	UBS TIPO 01 - BAIRRO SÃO CRISTÓVÃO - MURIAÉ/MG	Folha:	06/12
Objeto:	PROJETO ESTRUTURAL		
Endereço:	RUA ITALIA, S/N. (ESQUINA COM RUA MAURITANIA), BAIRRO SÃO CRISTÓVÃO - MURIAÉ/MG		
Proprietário:	PREFEITURA MUNICIPAL DE MURIAÉ/MG		
Contratante:	ASSOCIAÇÃO MUNICIPAL DA MICRO-REGIÃO DO MÉDIO RIO POMBA - AMERP		
Município:	MURIAÉ		
Comarca:	MINAS GERAIS		
Estado (UF):	MINAS GERAIS		
Descrição:	DETALHAMENTO DAS VIGAS DO TÉRREO (02/02)		
Data:	01/03/2023	ART:	MG20231952056

Áreas:		PROPRIETÁRIO:	
TÉRREO	199,21 m²	PREFEITURA MUNICIPAL DE MURIAÉ	
1º PAVIMENTO	171,33 m²	CNPJ: 17.947.581/0001-76	
ÁREA TOTAL	370,54 m²		

CONTRATANTE:	
ASSOC MUNIC MICRO-REGIÃO MÉDIO RIO POMBA-AMERP	
CNPJ: 20.350.328/0001-45	
RESPONSÁVEL TÉCNICO:	
ENG. HENRIQUE VITAL DO CARMO FREITAS	
ENGº CIVIL- CREA MG 188562	

Aprovação:



**6 D ENGENHARIA E PROJETOS**

Associação dos Municípios da Microrregião do Médio Rio Pomba

RUA EDMUNDO GERMANO Nº 35 - CENTRO - MURIAÉ - MG  
TELEFAX - 3722-1094 - E-MAIL - AMERP@AMERP.COM.BR