

P14

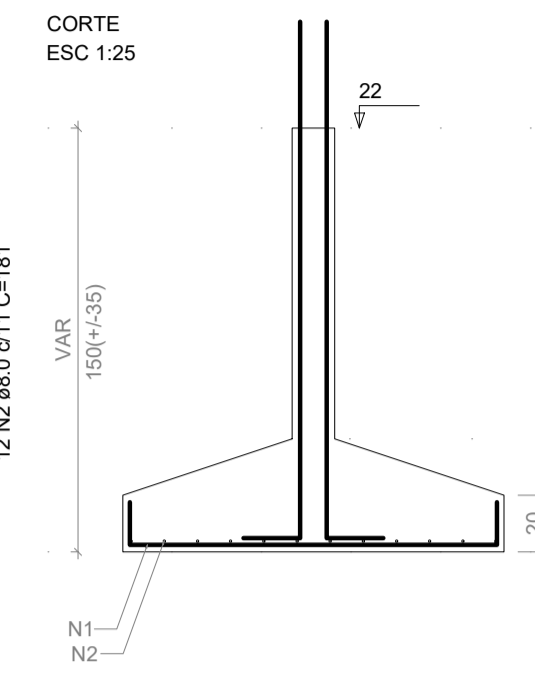

P18

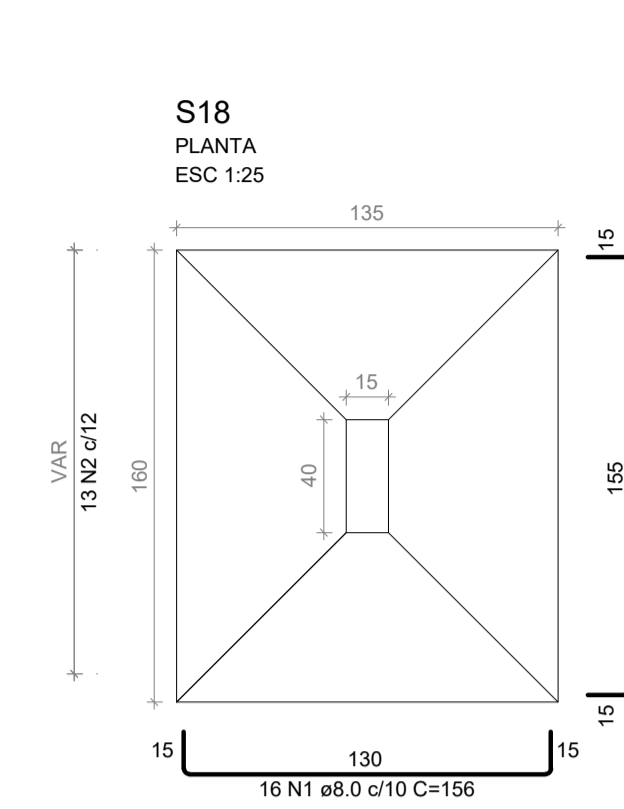
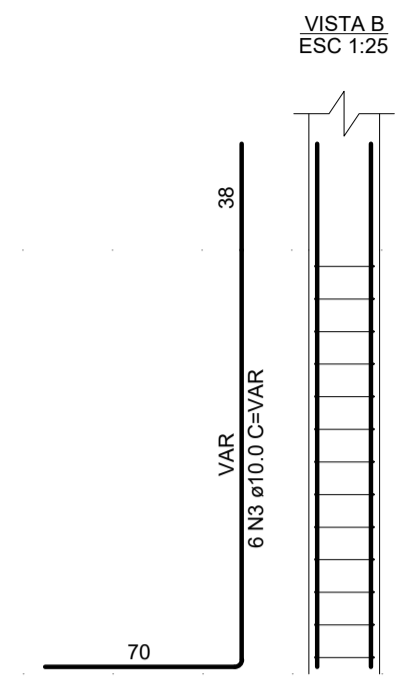
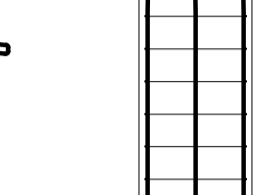
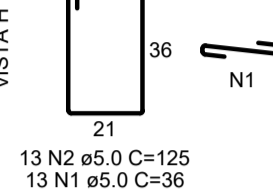
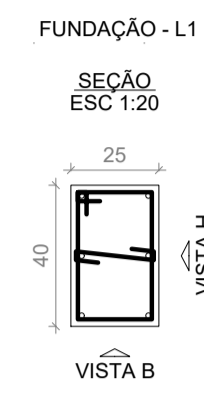
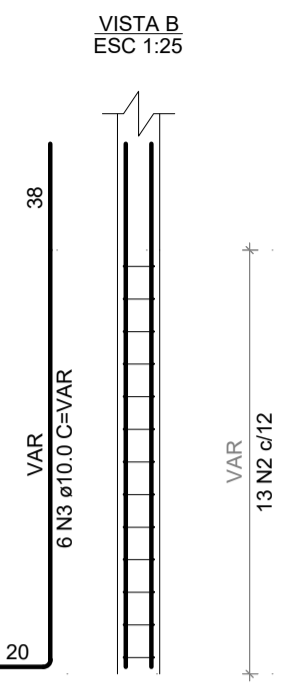
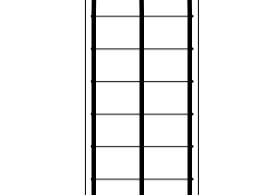
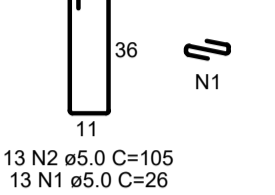
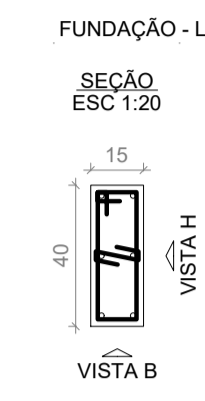

RELAÇÃO DO AÇO

ELEMENTO	AÇO	N	DIAM (mm)	QUANT	C.UNIT (cm)	C.TOTAL (cm)
P14	CA60	1	5.0	13	36	468
	CA60	2	5.0	13	125	1625
	CA50	3	10.0	6	VAR	VAR
P18	CA60	1	5.0	13	26	338
	CA60	2	5.0	13	105	1365
	CA50	3	10.0	6	VAR	VAR
2xP22	CA60	1	5.0	26	36	936
	CA60	2	5.0	26	125	3250
	CA50	3	10.0	12	VAR	VAR
P23	CA60	1	5.0	30	36	1080
	CA60	2	5.0	10	125	1250
	CA50	3	12.5	14	VAR	VAR
P24	CA60	1	5.0	13	36	468
	CA60	2	5.0	13	125	1625
	CA50	3	10.0	6	VAR	VAR
S14	CA50	1	8.0	13	156	2028
	CA50	2	10.0	9	145	1305
	CA50	1	8.0	16	156	2496
S18	CA50	2	8.0	12	181	2172
	CA50	1	8.0	20	136	2720
	CA50	2	8.0	18	151	2718
S23	CA50	1	12.5	13	214	2782
	CA50	2	12.5	11	229	2519
	CA50	1	8.0	13	131	1703
S24	CA50	2	8.0	11	146	1606

RESUMO DO AÇO

AÇO	DIAM (mm)	C.TOTAL (m)	PESO + 10% (kg)
CA50	8.0	154.4	67
	10.0	80	54.2
	12.5	96.7	102.5
CA60	5.0	124	21
PESO TOTAL (kg)			
CA50	223.7		
CA60	21		

Volume de concreto (C-25) = 4.33 m³
Área de forma = 20.73 m²

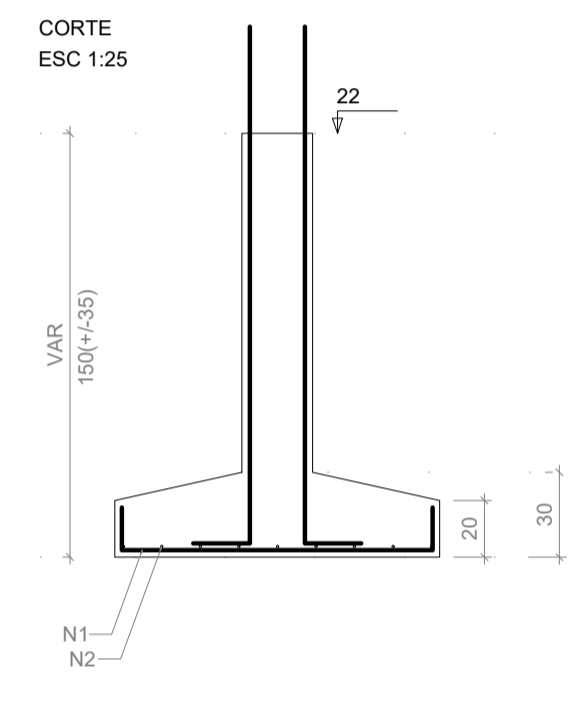
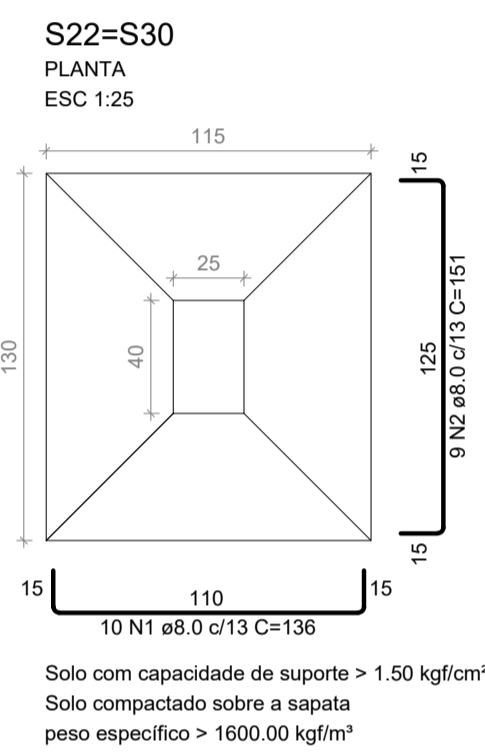

P22=P30

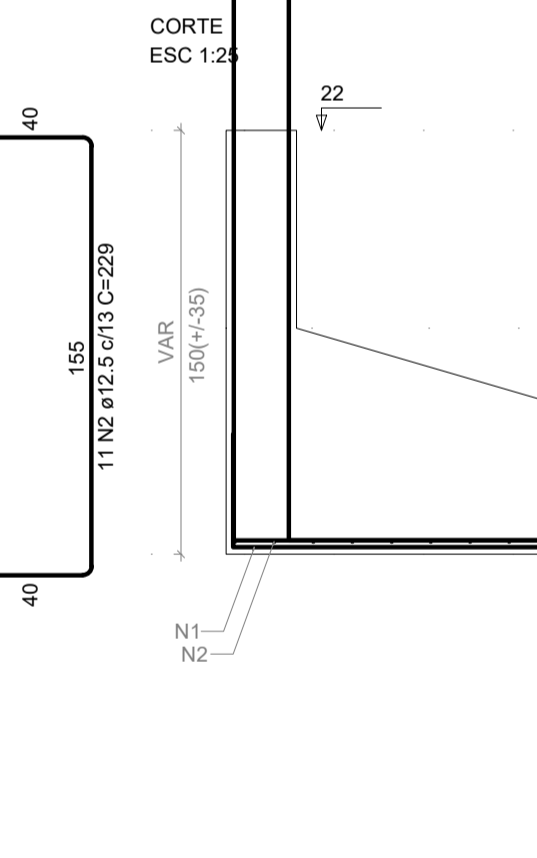
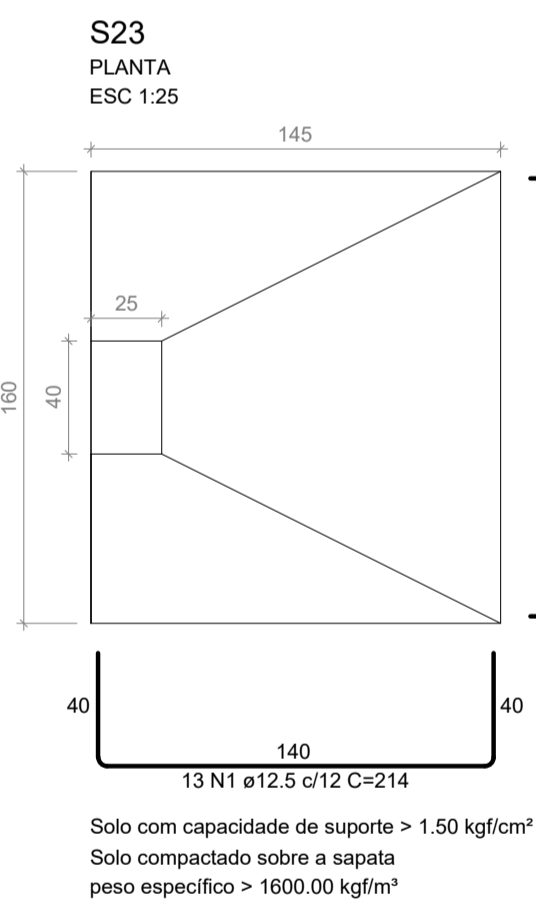
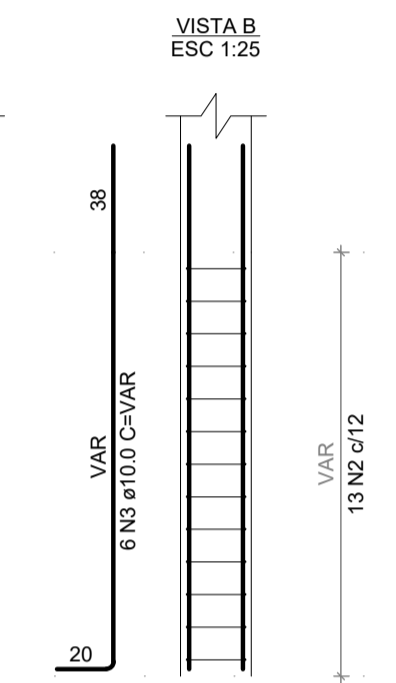
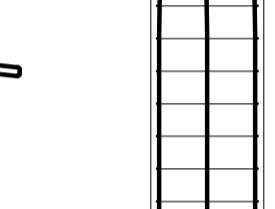
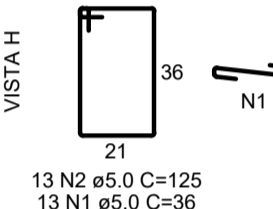
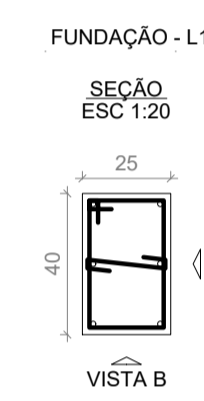

P23

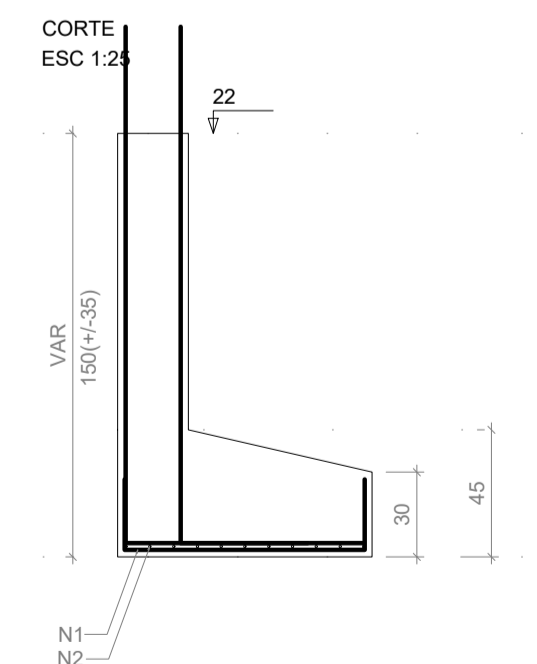
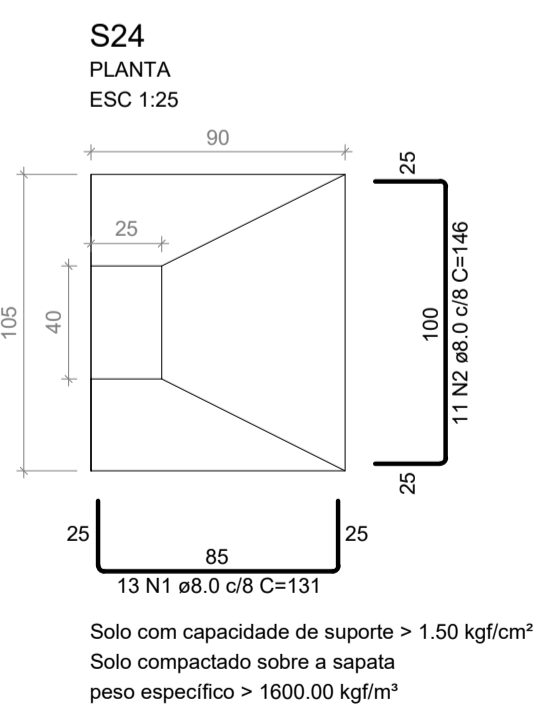
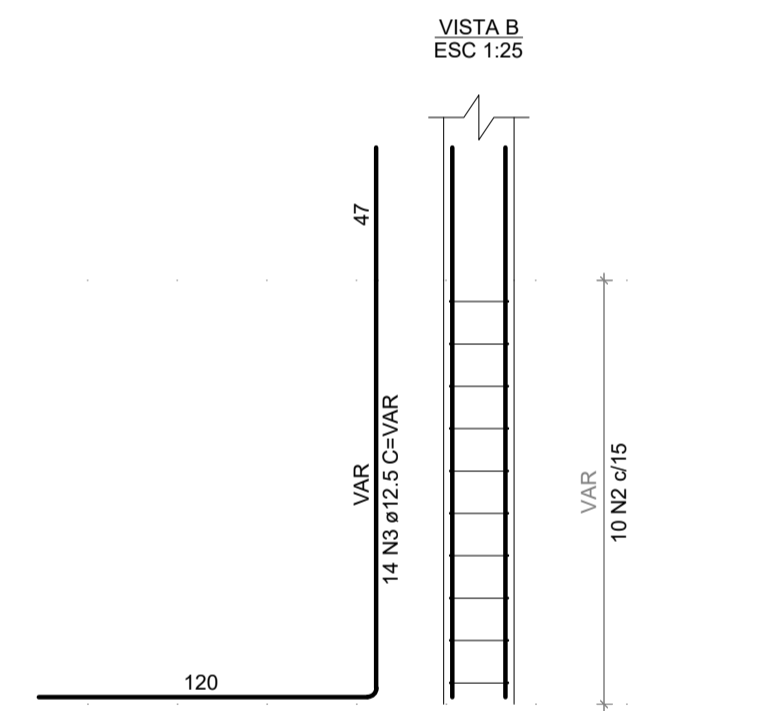
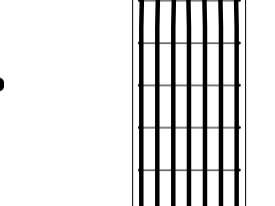
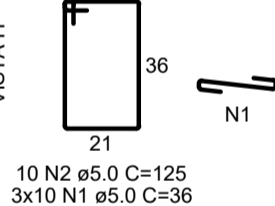
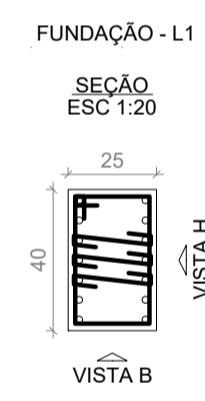

P24

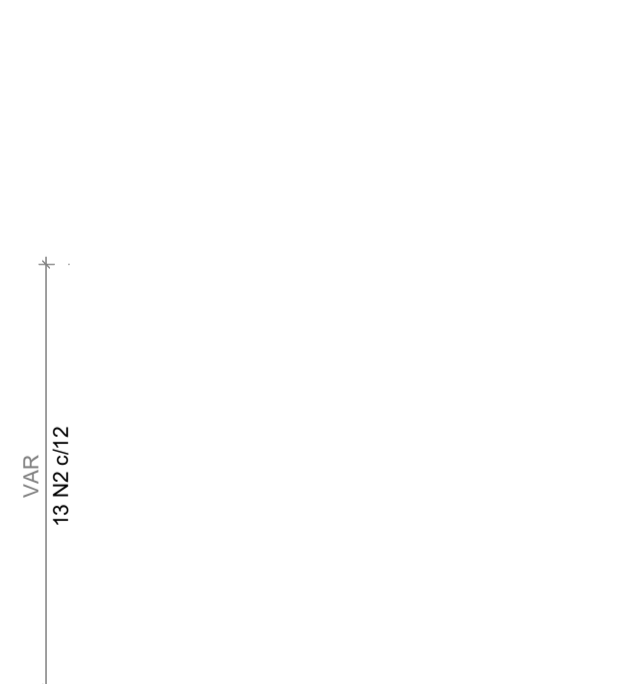
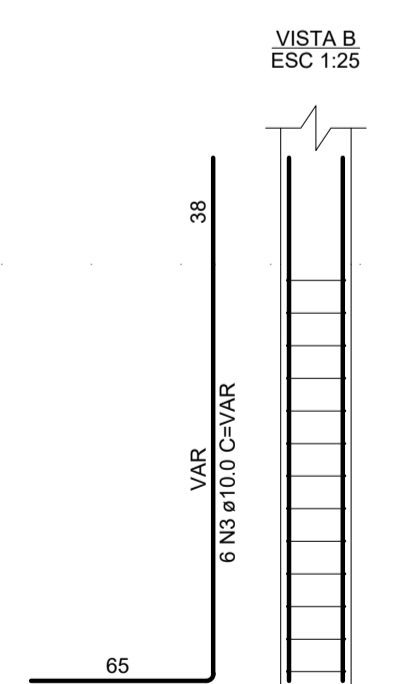
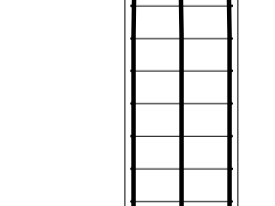
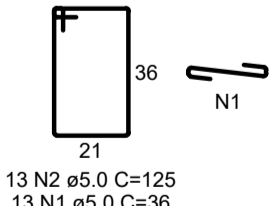
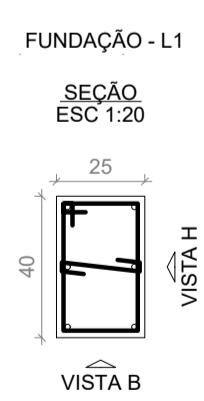



PREFEITURA MUNICIPAL DE MURIAÉ
SECRETARIA MUNICIPAL DE OBRAS PÚBLICAS

PROJETO ESTRUTURAL

PROJETO DE SAPATAS 2-5

<p>PREFEITURA DE MURIAÉ / CNPJ: 17.947.581/0001-76</p> <p>SECRETARIO DE OBRAS PÚBLICAS:</p> <p>MARCOS GUARINO DE OLIVEIRA</p> <p>JORGE FERES FILHO</p> <p>R. T. PROJETO:</p> <p>ARLAN DO CARMO MENDONÇA ENGRº CIVIL - COREA MG. 177324/D</p>	<p>DESCRIÇÃO:</p> <p>PROJETO ESTRUTURAL PARA CONSTRUÇÃO DE UMA UBS NO BARRIO INCONFIDENCIA</p> <p>LOCAL:</p> <p>RUA CLAUDIO MANOEL DA COSTA, ESQUINA COM A RUA ALVARENGA PEIXOTO-8, INCONFIDENCIA - MURIAÉ - MG</p> <p>ARQUIVO: PROJ. ESTRUTURAL UBS INCONFIDENCIA .DWG</p> <p>ESC. INDICADAS</p> <p>FOLHA:</p> <p style="font-size: 1.2em; font-weight: bold;">07/34</p>
--	---